

• • •
• • •
• • •
• • •
• • •

apollo Underwater vehicle
av-2 EVOLUTION
instruction manual



Introduction

Thank you for purchasing an apollo underwater vehicle.

The apollo underwater vehicle is revolutionary new underwater vehicle equipped with functions and features that set it apart from previous models and other brands.

Hands-free riding with the scooter saddle (PATENTED)

Hands-free is an innovative riding style that allows an operator to steer the scooter with body movement; much like a seal.

This inline body placement is more streamlined to effectively decrease fatigue, reduce air consumption, and extend your dive time. Go further, get there faster, and have a lot more fun along the way.

The hands-free riding style increases your options while diving.

You are no longer limited to the hands-on riding style required by other vehicles.

The possibilities are endless.

Variable speed control

Quick and smooth speed control is now at your fingertip.

Speed adjustments are made via an accelerator lever that changes the rotational speed of motor while vehicle is in use.

Adjustments are very smooth, allowing user to fine tune speed.

These enhancements are a significant improvement on the apollo vehicle series.

This new design provides a far more advanced control system than any other underwater scooter available.

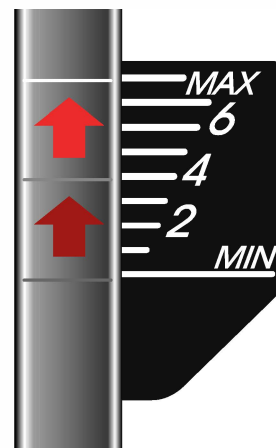

The apollo underwater vehicle is not heavy burden

The hands-free riding style decreases fatigue, reduces air consumption, and extends your dive time.

In the past some divers have become fatigued from the energy and effort required to hold and steer an underwater vehicle.

In addition to being a potential source of fatigue, the traditional hands-on riding style requires the user to place themselves above the vehicle rather than inline.

Improvement in transportation options

The apollo underwater vehicle improves your ability to transport items underwater.

Your hands are free to carry what you need.

The innovative apollo underwater vehicle challenges divers to create and find new techniques and methods of use.

Go out and enjoy diving with this great new generation diving product.

If you want more information about apollo DPV, please check website.

Contents

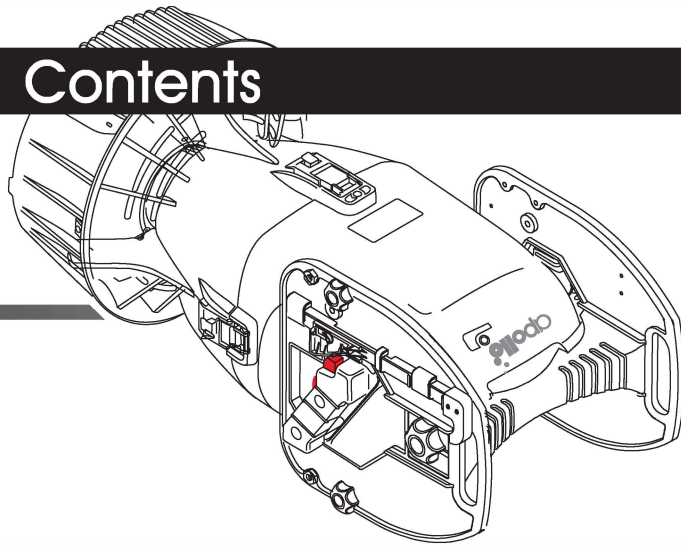

Instruction manual

P1	Introduction	
P2	Contents	
P3	Before reading the manual	
P4	Main warnings and notes	
P5	Specification	Each part name/spec
P6	Specification	Exclusive battery/charger
P7	Preparation	Charging the battery
P9	Preparation	Battery warranty/ Battery care
P10	Preparation	Single hand unit (Optional)
P11	Preparation	Checking before use
P14	Operation and use	Entry method
P16	Maintenance	Maintenance after use
P17	Maintenance	Note on maintenance and storage
P18	Trouble shooting	The propeller doesn't rotate even through the throttle lever is activated

Riding manual

<https://www.apollosportsusa.com/support.html>



Before reading the manual

Items with the following headings marked with this symbol "⚠" describe scuba diving techniques and how to handle diving equipment.

These sections must be completely understood, so be sure to read them with special care.

DANGER

Failure to read understand and obey the instructions under this heading may lead to accidents that may result in serious injury or death.

CAUTION

Failure to obey the instructions under this heading may lead indirectly to accidents that result in serious injury, death and or serious damage to equipment.

WARNING

Failure to obey the instructions under this heading may lead to minor accidents and/or damage to equipment.

DANGER

- It is extremely important that scuba divers using this product have undergone theoretical and practical training given by an internationally-recognized entity providing diving instruction.
Due to safety considerations, those who have not obtained a C-Card (attesting to the completion of training) from an entity providing diving instruction must not under any circumstances use this product.
(This does not apply to those using this product during training, under the supervision of an instructor attached to an entity providing diving instruction.)
Amateurs lacking knowledge of basic scuba diving techniques risk serious injury or death.
- Never scuba dive alone. Always dive under the buddy system.
Diving alone could lead to serious injury and death.
- Due to the speed of the apollo underwater vehicle depth & pressure change may happen faster than usual.
The diver must be aware at all times with regards the status of his depth and direction and carefully monitor his ascent rate as rapid surfacing and collisions could cause serious injury or death.
Please practice driving at low speed until you become accustomed to the handling of the scooter.

CAUTION

- Make sure you are in good physical condition before you scuba dive.
If you begin to feel anxious, cold, tired or unwell, do not over exert yourself and stop your dive.
- Never take alcohol or medicines (especially a nasal spray or medicine for a cold) before scuba diving.
Those who are in poor physical shape or suffer from a chronic ailment should consult a doctor before considering diving.

WARNING

- Before deciding to use your scooter in an adverse environment or special situation please consult with a qualified instructor at the place of purchase prior to undertaking your dive.

Main warnings and notes

CAUTION	Please only use our purpose-built battery and purpose-built charger.	Otherwise there is a danger of an explosion and fire.
CAUTION	Please do not change, remodel or disassemble.	There are dangers of the explosions and of fire if the electric circuit is tampered with. There are dangers of damage and water leaks in the body and circuits.
CAUTION	Please do not touch unnecessarily any moving parts (especially the propeller).	There is danger of injury.
CAUTION	Please do not touch the electrodes etc.	There is danger of electric shock because of high currents and voltage.
CAUTION	Please do not drive the scooter to the surface as there are dangers caused by rapid ascent.	The rapid pressure decrease associated with a rapid ascent may cause decompression disease or embolism.
CAUTION	Please only charge the battery in a well-ventilated area and keep it away from an open flame.	Hydrogen gas is generated from the battery while charging. There are possibilities of poisoning and fire.
CAUTION	Please ensure that string, hose, hair or foreign objects do not become entangled in the propeller. Remove the battery before attempting to disentangle any items should the propeller become obstructed.	There is a possibility of injury.
CAUTION	Please do not jump into water with the scooter.	The inertia and weight of the scooter is dangerous and could cause injury.
CAUTION	Please do not throw the scooter from a high place.	The inertia and weight of the scooter is dangerous and could cause injury.
CAUTION	Please do not enter with the scooter when you are boat diving. Have the scooter passed down to you.	The inertia and weight of the scooter is dangerous and could cause injury.
CAUTION	If your scooter has stopped abnormally or been for repair please do not run it for a long distance until after you have confirmed it is safe.	An unknown fault or unfinished repair may cause an unexpected accident.
WARNING	Please execute a thorough check prior to use.	An accident may be caused by a malfunction after it enters the water.
WARNING	Please do not run the scooter for more than five seconds out of water.	The seal part on the propeller shaft is damaged by frictional heat, and there is a possibility of water leakage.
WARNING	Please take careful note of your surroundings and circumstances prior to preparing your equipment on land and in the water.	Equipment and materials may be damaged by unexpected operation.
WARNING	Please disconnect the battery terminal when the scooter is not in use.	Unexpected operation due to the switch being accidentally operated may cause an unexpected accident.
WARNING	Please check the main body O-rings for impurity and dust before usage.	There is a possibility of water leakage by imperfect sealing, which may cause damage and an unexpected accident.
WARNING	Please do not use other than the specified silicone grease lubricant supplied by Nippon Sensuiki.	Damage may be caused to the materials the scooter is made from by using lubricants other than what Nippon Sensuiki Co., Ltd. supply. This in turn may cause an unexpected accident.

The above-mentioned table does not mention all prevention matters that could cause danger and injury. Please carefully read and follow the instructions whenever you see the "" symbol in this book.

Specification

The av-2 EVOLUTION name of each part

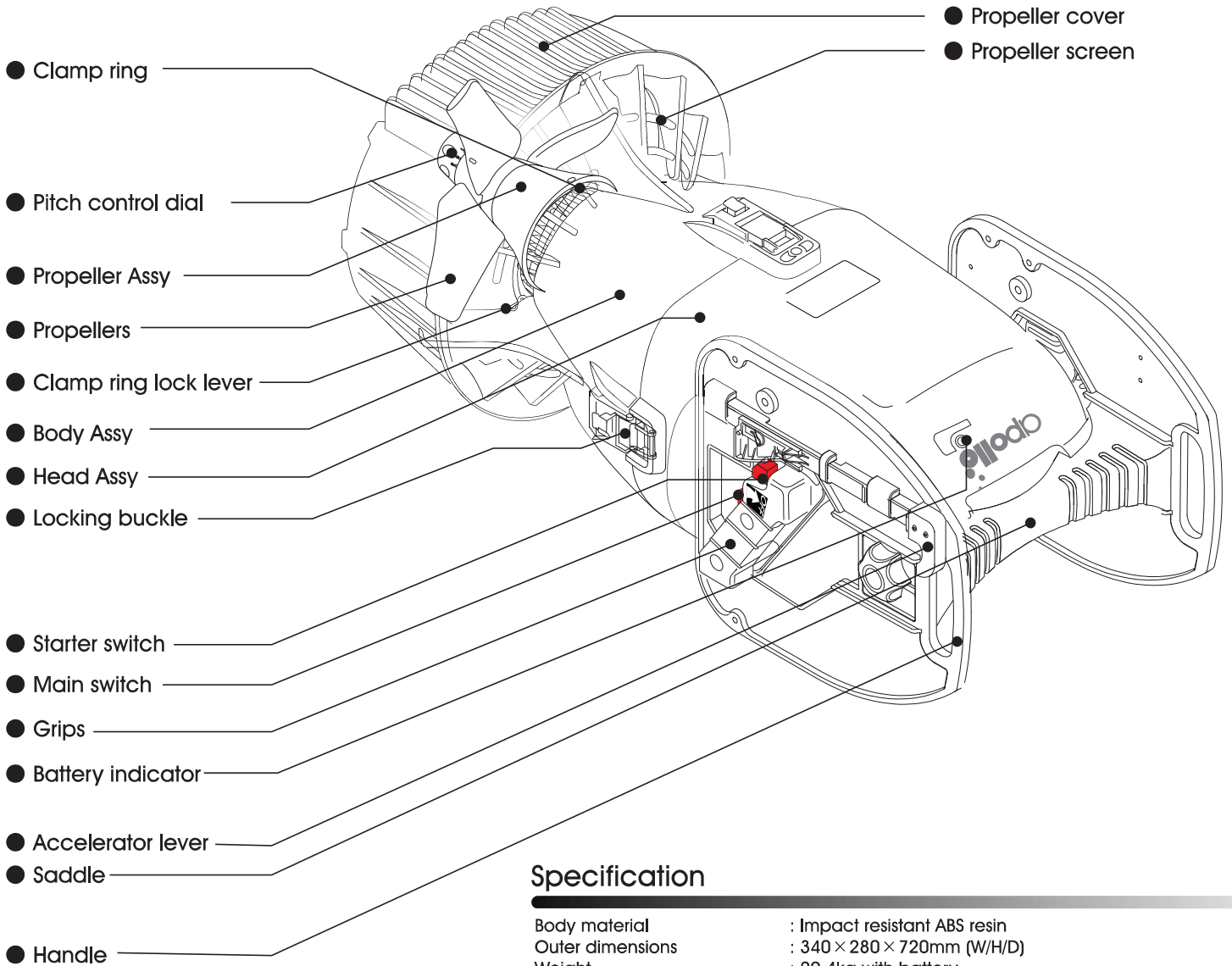

Specification

Body material	: Impact resistant ABS resin
Outer dimensions	: 340 × 280 × 720mm (W/H/D)
Weight	: 20.4kg with battery : 11.4kg without battery
Submerge weight in seawater	: 0.5kg : 0.95kg with single hand unit
Motor	: DC brush-less motor
Decelerator	: Planetary gear
Speed	: 0 to 4.5km/h It depends on the divers posture, physique and equipment.
Maximum operational depth	: 70m Performance when new. This performance will deteriorates with age.
Run time at cruising speed	: Approx. 100min.
Cruising distance	: Approx. 9,600m Run time at cruising speed and cruising distance vary depending on the battery, propeller pitch, and etc..
Speed control	: Motor speed control 3-stage pitch variable propeller
Safety device	: Over current detection Water leak detection Battery remaining capacity indication
Accessories	: O-ring seal for the main body : O-ring seal for the propeller end of the body : Silicone grease : Instruction manual

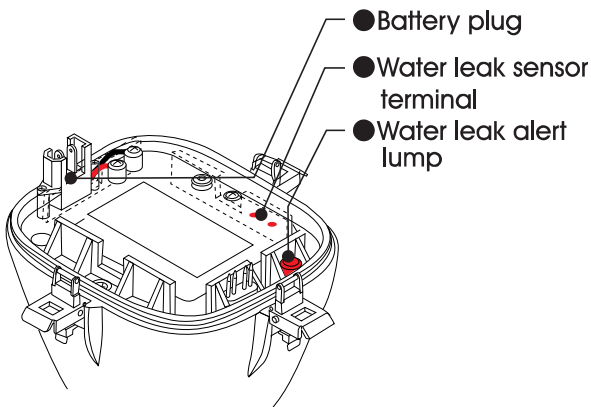

The maximum operational depth will decrease with age. This is due to the aging of the ABS resin used for the housing due to ultraviolet rays and ozone. When it is new, the maximum operational depth is 70m, based on in-house test data, however after about 3 years it will degrade to about 50m, and will decrease over the years.

Also, the degree of degradation is not constant depending on the operation and storage environment. Please be especially careful when frequently using at a great depth.

Specification

Separately purchased accessories

- Lithium ion battery 27Ah for av-2 (Use only batteries supplied by Nippon Sensuiki)
- Charger for lithium ion battery for av-2 (Use only the specific charger supplied by Nippon Sensuiki)

⚠ CAUTION

- Please never use other batteries than those supplied by Nippon Sensuiki. (Supplied separately)
- Please never use other chargers than those supplied by Nippon Sensuiki. (Supplied separately)

Exclusive battery for av-2 series

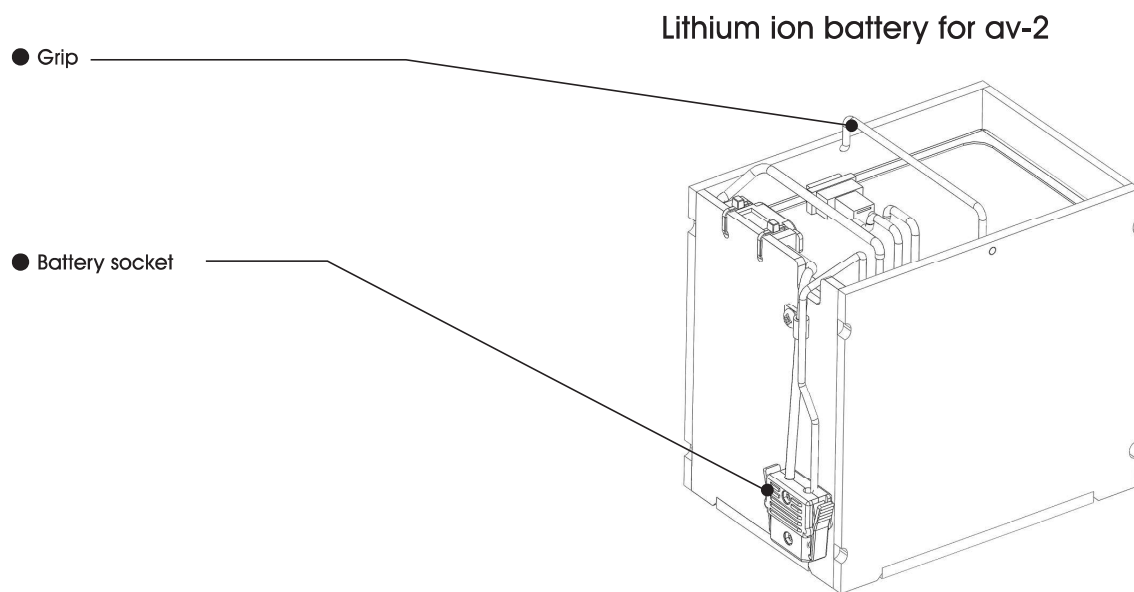

Exclusive battery charger for av-2 series

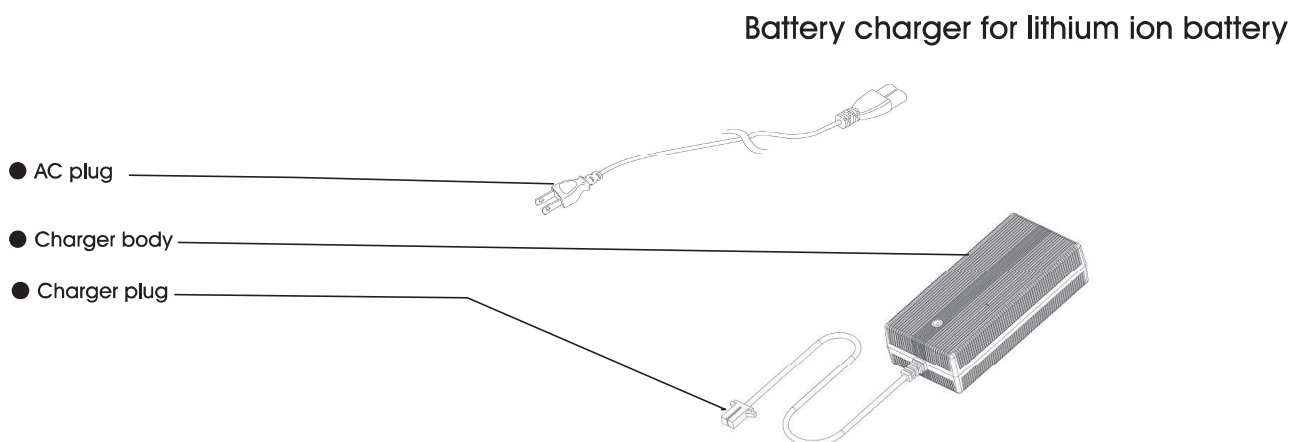

⚠ CAUTION

- Please refer to the handling manual that is attached to each product explaining usage of the battery and charger.

Preparation

Charging the battery

■STEP1 Preparation for charging.

- Please stand the scooter vertically on the propeller cover. Make sure it's on a flat stable surface so that it cannot fall over and cause damage to the propeller cover and blades.
- If the scooter is wet, wipe all moisture off completely.

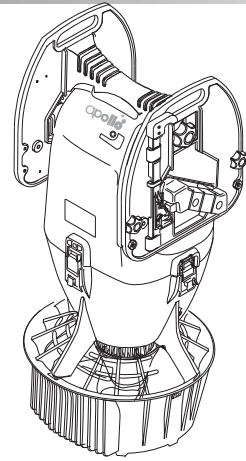

■STEP2 Unfasten the locking buckles.

- Unfasten four locking buckles on the body seal. A locking mechanism is attached to the locking buckle to prevent it from releasing as a result of unexpected shocks.

- ① First, while pushing the square button in the center of the locking buckle, lift the end of the buckle.
- ② Next, after releasing the buckle hook, flip the buckle downward. Release all four parts.

If with the single hand unit, unnecessary to disassemble the single hand unit when removing the head Assy.

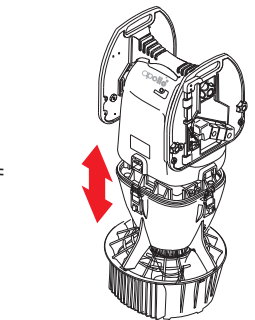
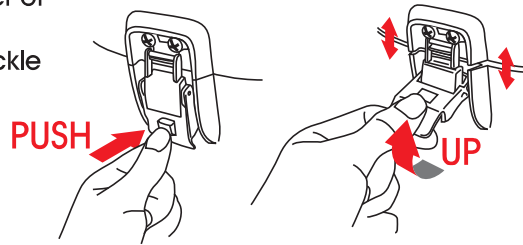

Remove the head Assy.

■STEP3 Removing the battery housing.

- It may be difficult to remove the battery housing (head Assy) due to negative pressure inside the body caused by contact with the O-ring, temperature variation and other factors. In this case, place the buckle latch under the locking hook and apply pressure with your thumb while pushing upwards. Do this on both sides of the scooter concurrently to break the seal and easily release the battery housing (head Assy).

If it is hard to remove head Assy . . .

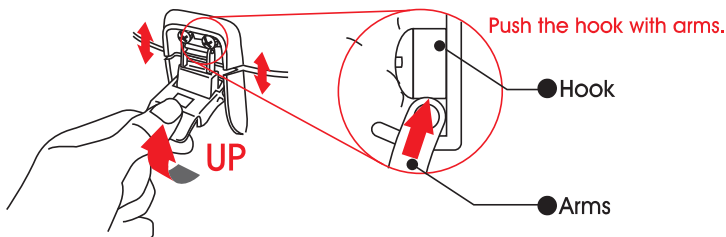

In addition, after you've removed the saddle panel, insert the driver, such as the hole is shown by the arrow, you can open the valve at inside. Please be pry gently in the direction of the arrow.

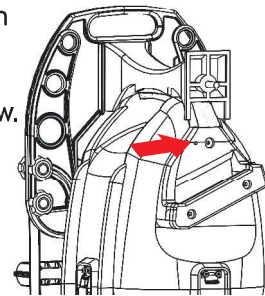

⚠ WARNING

Precautions concerning the handling of the battery housing (head Assy) after removal.

- Silicone grease has been applied to the seals on the battery housing. Sand and other debris easily stick to this. Be careful to avoid this situation.
- Water leakage is caused almost entirely by sand or other debris adhering to the seal area.
- Please put the battery housing (head Assy) in a safe clean place lying down on the ribs located on its base.
- Please do not place it on sand or on rocks etc.

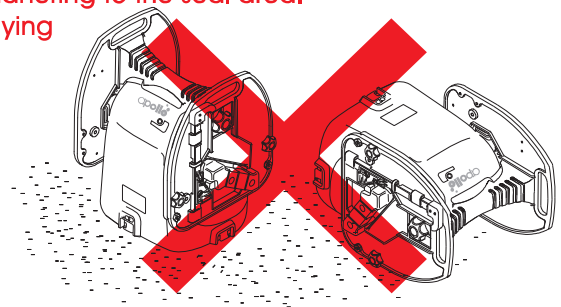

Preparation

■STEP4 Releasing the battery connector plug.

- Hold and squeeze the release levers on both sides of the battery connector plug and pull upwards.

⚠ CAUTION

- Altering the battery connector plug in any way is very dangerous and should not be done. Any alterations will cause unexpected trouble.

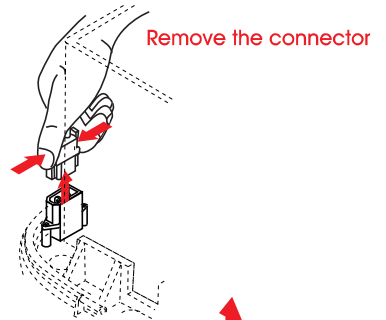

■STEP5 Removal of the battery.

- Hold the grip of the battery firmly and lift it away from the body. Place it on a clean and dry flat stable surface.

⚠ WARNING

- The battery is quite heavy, so be careful not to get your fingers pinched or to drop it onto your feet.

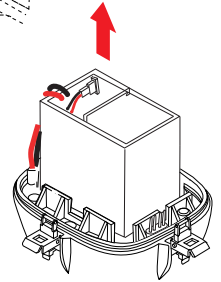

■STEP6 Connecting the exclusive charger to begin recharging.

⚠ CAUTION

- You must use the correct exclusive charger suitable for the type of battery being used. Please refer to the handling manual that is attached to each product about the battery.

- ① First, connect the AC (alternating current) plug of the charger to a domestic outlet.
- ② Next, connect the socket from the battery to the plug on the charger. The charging will automatically start upon connection after the power is turned on at the domestic outlet.

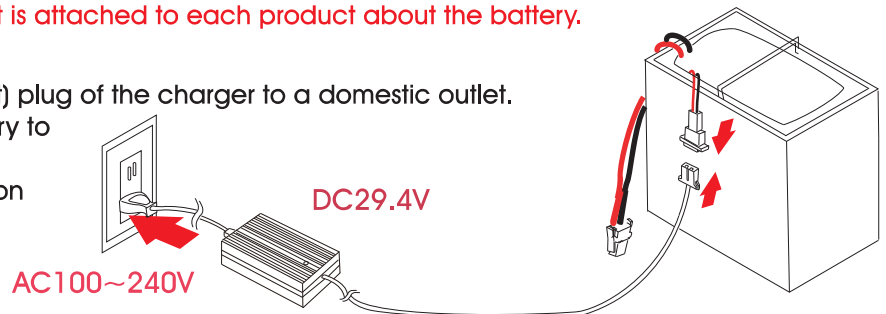

⚠ CAUTION

- The connector is polarized, so when connecting, insert in a direction so it will smoothly enter the connector receptor.

Charging time of the charger

The color of LED will indicate when charging is completed.
Charging : Red light ▶▶▶ Finished : Green light

- The red is changed into green as the charge progresses.
- A green lamp shows when the battery connector is not connected (open circuit) but the power is on.

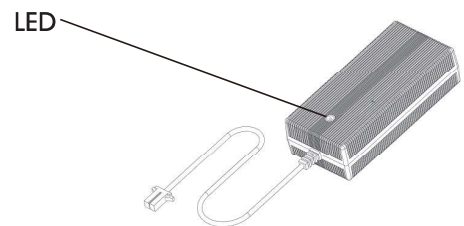

■STEP7 Disconnect the charger when charging is completed.

The battery charger automatically changes into trickle charge mode after charging is complete. Please do not keep the trickle charging for extended period of hours exceeding a day as it may damage the battery life.

- ① At first, turn the power off and remove the AC plug from the domestic outlet.
- ② Next, remove the plug of charger.

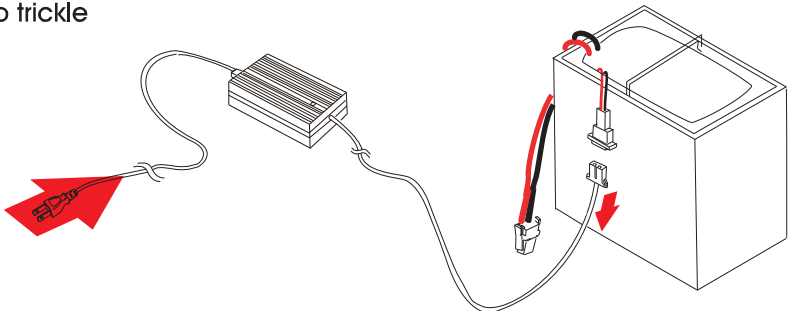

■STEP8 Charge completion.

⚠ CAUTION

- Please do not set the battery into the scooter for at least 30 minutes after completing the charge. Please do not use if the battery become high temperature.

Preparation

Usage of batteries except Lithium ion battery

- In case of using with exclusive battery for av-2 sold in the past except lithium-ion battery, please set a battery changeover switch to Lead-Acid/Ni-MH as illustrated.

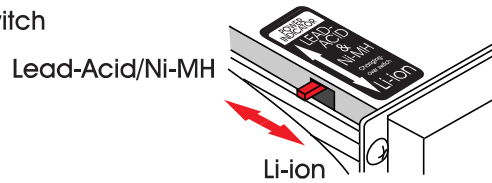

Warning

- Even if it is equipped with Lead-Acid battery or Ni-MH battery in full charge and turn on a main switch, battery indicator does not always display FULL(Green LED won't turn on)

Battery select switch

About battery care

HOW TO CARE BATTERY

- Battery is not charged when delivery so that charge it when in use.
- If the battery is not in use for a long period, it may affect a lost of capacity by self-discharging.
- If storage temperature is over 25°C(77°F), charge once for every 2 month. Even if not exceed over 25°C(77°F), charge once for every 3 month.
- Directly contact us when fuse is cut off.
- Do not over discharge until a propeller won't turn or slowly turn around.

Li-ion battery for av-2

Temperature range for battery

U S E : -20°C~60°C (-4 ~ 140° F)

STORAGE : -10°C~45°C (14 ~ 113° F)

CHARGE : 0°C~45°C (32 - 113° F)

- **The protective circuit is equipped in the lithium-ion battery inside.**
When this circuit stops to discharge, be careful as you can not reset by turning main switch on again.
Only it can be reset by re-charging the battery.

Warning

- Never throw the battery into water, keep it under dry, shady and cool circumstance when not use.
- Never keep the battery beside high temperature source examples: fire, heating machine and ect.
Never throw the battery into fire or heating machine.
- Never upside down the positive and negative.
- Never cut the battery in socket directly
- Never connect the positive and negative of battery with metal.
- Never knock, throw or trample the battery.
- Never cut through the battery with nail or other edge tool.
- Never use or keep the battery under the high temperature. Otherwise it will cause battery heat, get into fire or lose some function and reduce the life.
- Never use the battery under strong static and strong magnetic field, otherwise it will destroy the protecting device.
- If battery leaked, the electrolyte get into eyes, please don't knead, please wash eyes by water and send to hospital. Otherwise it will hurt eyes.
- If battery emit peculiar smell, heating, distortion or appear any unconventionality during using, storage or charging process, please take it out from device or charge and stop using.
- If the pole of the battery plug was duty, please clear it before using.

Preparation

Placement for the single hand unit

Picture for avx

■STEP1 Preparation for placement

Use Super Knob and M6 screw of the scooter saddle.

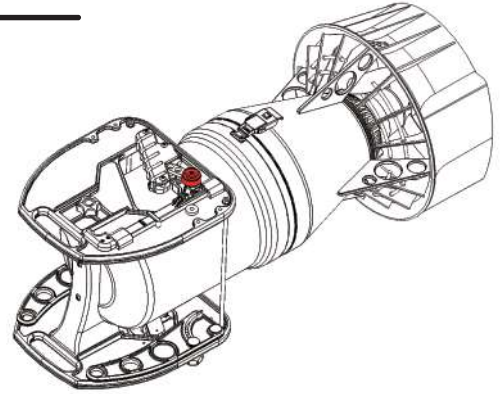
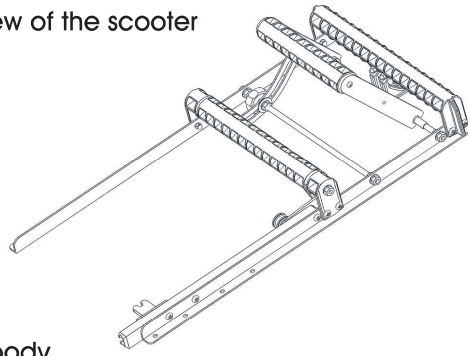

■STEP2 Placement to the body

1. Put the Stay of the Propeller Cover; place the Handle ASSY to the Propeller Cover.

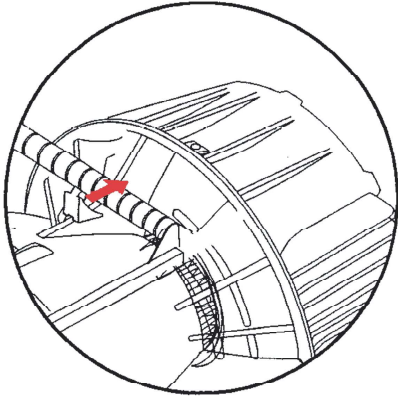

Please insert into the propeller cover diagonally.

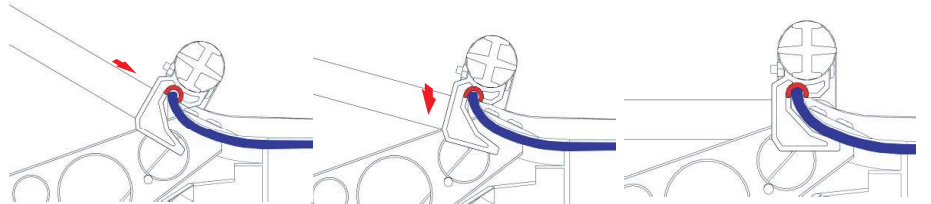

Place the Handle ASSY well to put it in top and bottom like above illustration.

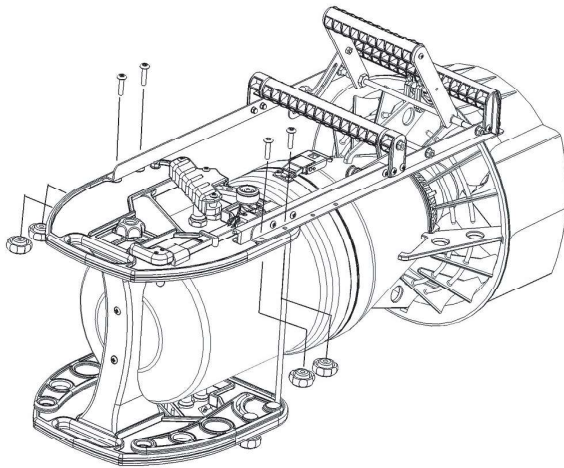
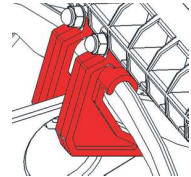

2. Fix the Saddle ASSY and the Handle ASSY by the Super Knob. Fit the Joint lever of the Handle ASSY into the Switch Cam to operate the switch lever.

3. Confirm operation of the switch lever after completion.

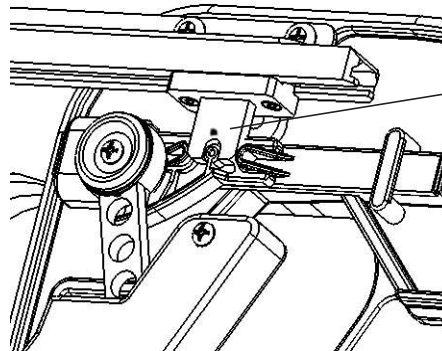

Fitting mark

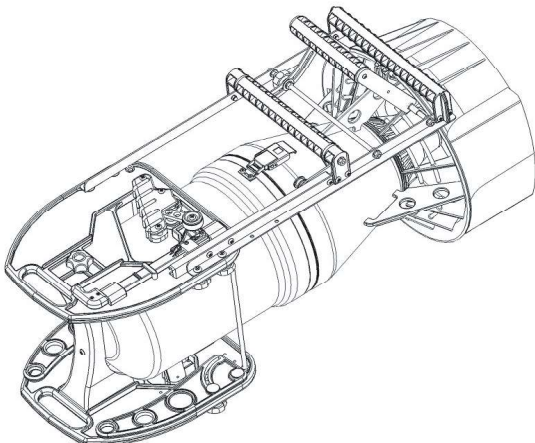

Preparation

Checking before use. (setting)

■STEP1 Set the battery.

① Please set the fully charged battery in the body housing in the correct position.

⚠ WARNING

- Please only use a fully charged battery otherwise damage will be caused.
Also check again that the correct charger was used with the correct battery.

② Next, the battery socket is connected with the body plug.
(Please always remove the connector when not in use or during travel to your destination.)

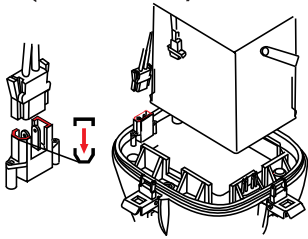

Connect the socket to right way.

③ At this time, confirm that the warning lamp isn't on.
Please do not use the scooter if the warning lamp is on as this may indicate a water leak has occurred.



■STEP2 Set the battery housing (head Assy).

- Please confirm that there is no debris adhering to the O-ring, O-ring groove or O-ring connecting surface.
Also confirm that there are no scratches and that an appropriate amount of silicone grease has been used.

① Check the switch of "Battery Selection Switch" to same position as the battery type.

② Place the battery housing (head Assy) carefully in position taking note that the ribs on the underneath of the scooter match up.

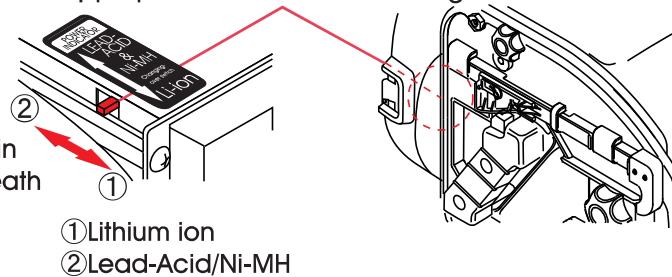

Battery Selection Switch

■STEP3 Checking the housing seal.

⚠ WARNING

- After setting the housing, confirm that there is a uniform space of about 0.5mm between the battery housing (head Assy) and the motor housing (body Assy).
If the space is less than 0.5mm or if the two parts are joined, there is the possibility of the O-ring coming out of the O-ring groove.
Confirm that this not the case before proceeding.

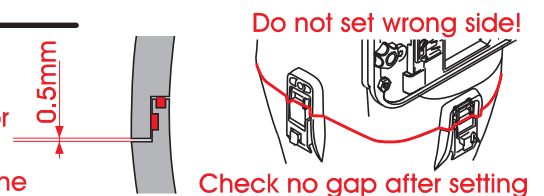

■STEP4 Checking the locking buckle.

- Pull up the lever by finger and check whether all buckles are locked securely.
- When the locking button (square shaped button) is deformed to inside, pull the button by finger to correct position carefully and check the locking action.

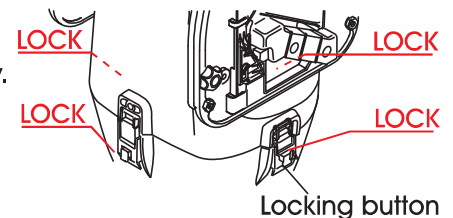

Preparation

Check before use. (confirming operations)

■STEP1 Turning on the main switch.

- ① Check your surroundings.
Always confirm that nothing can obstruct or become entangled in the propeller.
- ② Place the scooter vertically on a level surface.
- ③ Turn on the main switch. It is located on the right hand grip.



■STEP2 Checking the battery indicator light.

- Confirm that all lights are illuminated. (i.e. Green, yellow, and red)
- In case of using Lead-Acid / Ni-MH battery, green LED does not always turn on even if at full charge.

Lights the Battery indicator ON

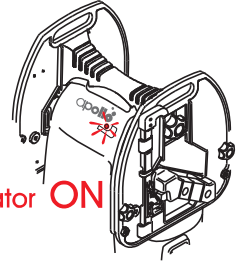

About battery indicator

- It is necessary to synchronize the battery indicator for each type of battery (Lithium ion or LEAD-ACID / Ni-MH) to ensure an accurate display of the remaining battery life. (Refer to STEP 2 on page 11)
- The display accuracy may be affected by an exhausted battery and ambient temperature. Please refer to the battery indicator as a rough guide only.
- Indicator operates following by battery voltage at propeller pitch 2 with full throttle. Please note that it can not be measured accurately because the battery voltage is recovered gradually when the motor is stopped.

■STEP3 Operate the motor.

- ① Push up the accelerator lever.
- ② Slowly push up and down on the accelerator lever.
- ③ Confirm rotational speed changes are occurring with vertical motion.
- ④ Also, confirm the sound of propeller for check.

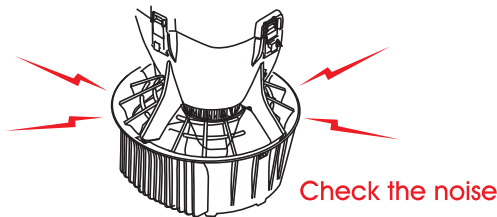
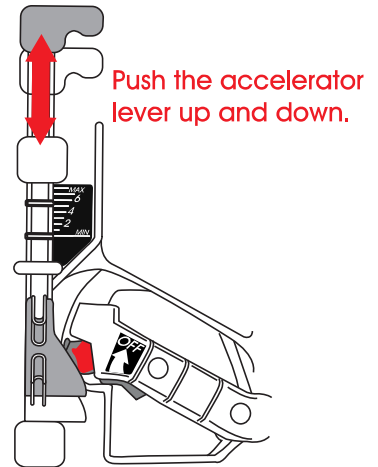
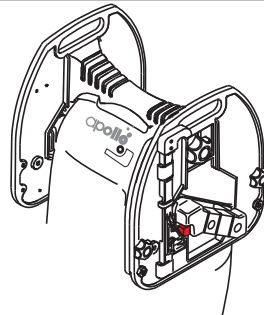

- ⑤ Check the battery indicator for battery condition with turning on the motor.



All colors are tuned on after full charged, then changed color with consumption.

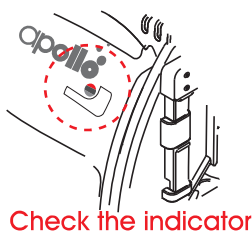

- ⑥ Take all pressure off the accelerator lever.
- ⑦ Confirm the rotation of the propeller has stopped completely.

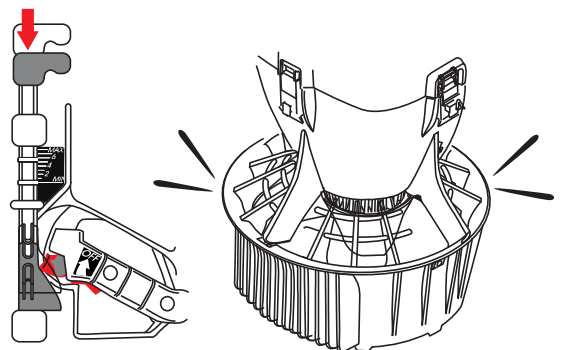

Preparation

STEP4 Turn off the main switch.

- Move the main switch to off position.
- Confirm that all battery indicator lights are off.



Main switch OFF

⚠ WARNING

- If switch is left on the standby current will continue to flow.
It is possible that damage will occur from over discharge of the battery.

STEP5 Using the variable pitch propeller.

- Lay the scooter down on a level surface.
- Pull and turn the pitch control dial knob to make adjustments to the propeller angle.
- Push the dial back after speed selection.

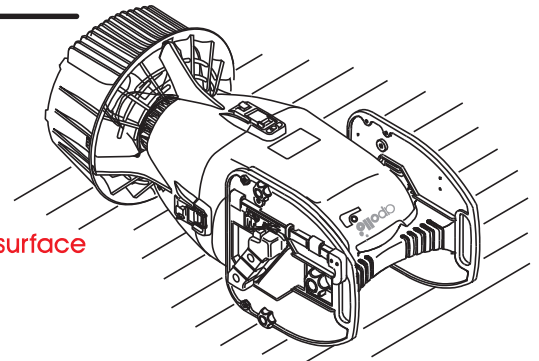

Lay the scooter down on a level surface

Pitch selection

	Acceleration	Maximum speeds	Battery consumption	
PITCH 1	●●●●●●	●●●●●●	●●●●●●	= Acceleration purpose (need more power for pulling a heavier person or weight - reduces battery life)
PITCH 2	●●●●○○	●●●●○○	●●●●○○	= Standard purpose (most efficient setting)
PITCH 3	●●○○○○	●●●●○○	●●●●○○	= Low speed purpose

- All apollo DPV: Confirm that pitch operation moves smoothly through the three stages.
- All apollo DPV: Recommended position is Pitch 2 or 3 because of low consumed power.

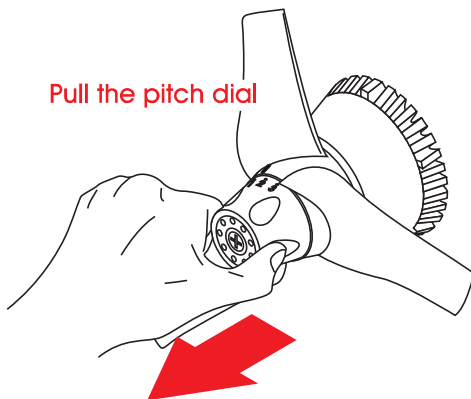

Pull the pitch dial

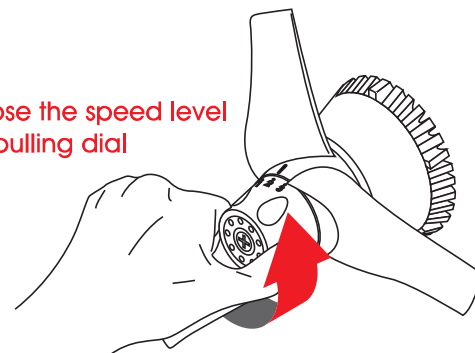

Choose the speed level with pulling dial

⚠ WARNING

- Do not miss the check before diving in order to prevent from serious injury.

Operation and use

Entry method

■STEP1 Entry from shore.

The scooter is very light when in the water - just slightly negative. While hands free riding it's very easy to use the scooter in shallow water even up to waist deep. You don't need to stay on the bottom in shallow water. You can enjoy cruising along the surface quite comfortably until you find a deeper area you would like to dive to.

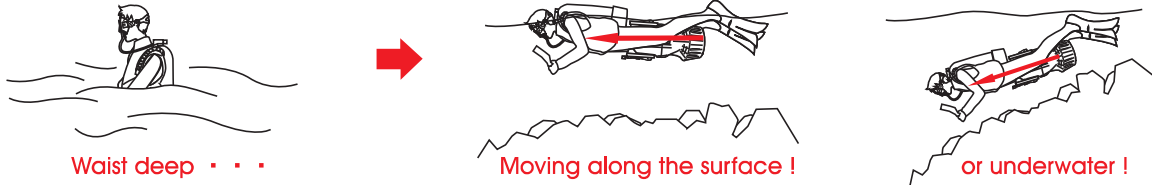

Waist deep . . .

Moving along the surface !

or underwater !

⚠ CAUTION

- Never jump into the water with scooter from a boat or any other elevated location. Never throw the scooter, as it is potentially very dangerous. Please refer to the boat entry method for further instruction.

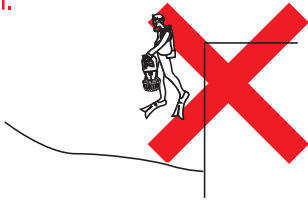

Don't jump from a high place with the scooter



Don't throw the scooter

■STEP2 Entry from boat and other elevated areas.

- Please secure the scooter by a lanyard or rope in the water or hand it to the diver after he or she has entered the water.
- When passing the scooter to a diver already in the water please lower the scooter in so the diver can easily grasp a handle or grip.

⚠ CAUTION

- Please turn off the main switch so that the propeller cannot operate by mistake when passing it to a diver.
- Do not enter from a boat or other elevated position while holding the scooter.



Do not enter the water while holding the scooter



Please turn off the main switch

Exit

■STEP1 Beach

It's recommended to drive the scooter up to waist deep water and leave it close to or on the edge of the shore. The scooter is heavy when out of water. It is strongly recommended that you remove your diving equipment on the shore prior to lifting the scooter.

■STEP2 Boat

Securely attach the scooter with a rope or lanyard to the boat. Lift the scooter from the water after the diver has exited.

Operation and use

How to operate.

■STEP1 Accelerator operation

apollo underwater scooter speed is controlled by the rotational speed of the propeller with the accelerator unit and by adjustment of the propellers pitch. The rotational speed of the propeller rises when the accelerator lever is pulled up. The rotational speed decreases when the accelerator is pushed down.

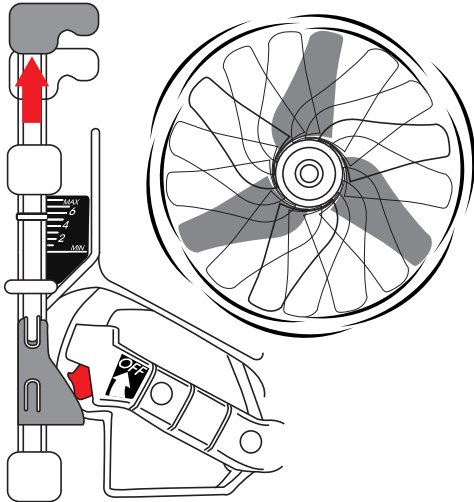

Pull out accelerator

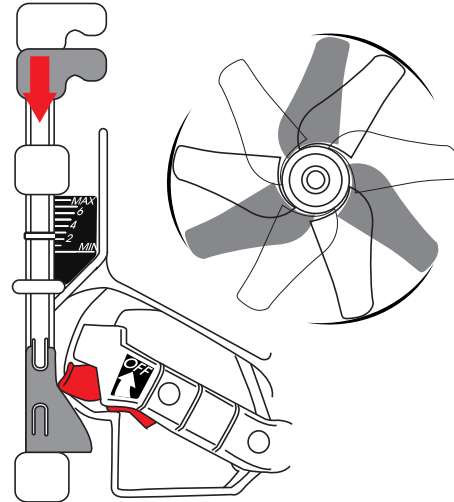

Push down accelerator

Overload protection safety sensor

apollo underwater scooter has a built-in safety device that protects the motor if overloading occurs. For example if rope gets wound around the propeller shaft the scooter will automatically stop. The scooter safety sensor protects the diver's safety from rotation rebound if the propeller becomes entangled or otherwise obstructed. The scooter is equipped with a safety sensor to protect the motor from burn out and deterioration caused by overloading.

If the safety device is activated, turn off the main switch once and it will be reset. After resetting, the motor should works as usual.

⚠ CAUTION

- If the motor has stopped please carefully check for debris that may be obstructing or entangled in the propeller area. Please ensure the debris is completely cleared away prior to resetting and reactivating the motor otherwise damage may occur.

Maintenance

Maintenance after use.

Please wash with tap water after use. Make sure to flush sand and other debris from around the propeller, switch, accelerator unit, and locking buckles.

■STEP1 Avoid salt build-up - desalt after use.

- Stand the scooter upright, and flush with tap water from your hose all salt, sand and debris. Take special care to efficiently wash the switch part of the accelerator unit, as this is a critical moving part during operation.
- With the scooter laid horizontally slowly rotate the propeller manually and wash using a hose all the joints and seam in and around this area.
- If possible, you can "desalt" the scooter in a large water tank if the diving store has this facility.

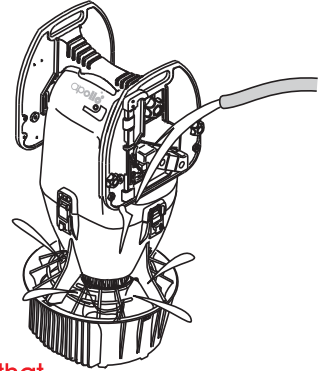

⚠ CAUTION

- Please do not activate the scooter until confirming that the surrounding area is safe and that no other equipment is in the tank as the propeller generates turbulence. Please never put your hand near or in the rotating propeller. A water tank that has not been refreshed may itself have excess salt and in this case will not provide a sufficient rinse.



■STEP2 Disassembling the propeller Assy.

⚠ CAUTION

- Please remove the battery from the scooter before working on the propeller area.

- ① Pull up the two clamp lock levers in order to unlock the clamp ring.
- ② Next, the clamp ring can be unlocked by rotating counter clockwise and matching the oval mark on the clutch/propeller housing. Then pull out the propeller housing.

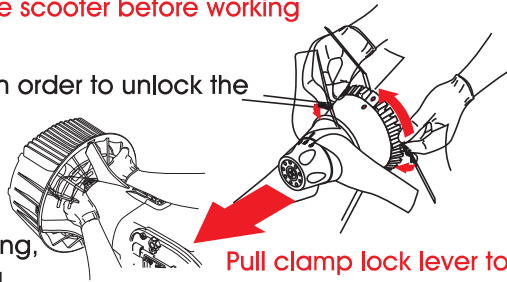

Pull clamp lock lever toward self and turn clamp ring.

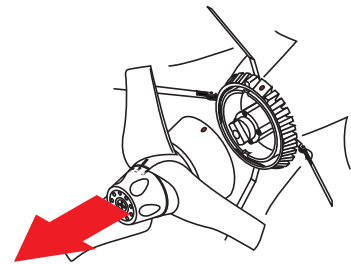

Remove propeller Assy

■STEP3 Check and cleaning of propeller Assy.

- Check to see if any water leakage has occurred inside the propeller Assy.
- If a little water is present please desalt it away, drain completely.

⚠ WARNING

- A small amount of water leakage (a teaspoon or so) is not abnormal and will not harm the operation of the scooter. However, if the propeller Assy is full of water then discontinue using the scooter as the propeller Assy area and rear seals of the scooter need to be overhauled before any further use.

In general many scooters have leakage weakness around the sealing area on the propeller shaft. If a seal becomes worn water can infiltrate the motor compartment and cause major damage. Scooter have greatly improved this area of weakness in comparison to other scooters. We specially designed a double sealing system for the propeller shaft by building a small watertight compartment between the first seal and the second seal. Even if water leaks into this area through the first seal into this compartment further leakage into the motor compartment is prevented. (PATENTED)

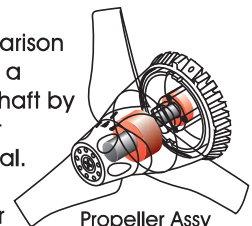

■STEP4 Set the propeller Assy.

- Please drain all water completely.
- Please check the O-ring, O-ring groove, and O-ring surface and remove any dust, sand or debris. Check for any scratches or damage to the O-rings and confirm an appropriate amount of silicone has been applied.
- Installation of propeller Assy is the inverse order to "Remove the propeller Assy". Please note that the propeller shaft needs to be seated correctly before pushing the propeller assembly down and relocking the clamp ring into position. You can find the right position by pushing down gently on the propeller Assy while slowly spinning the propeller manually.
- Please confirm the clamp ring is seated down correctly and that the O-ring is not protruding.

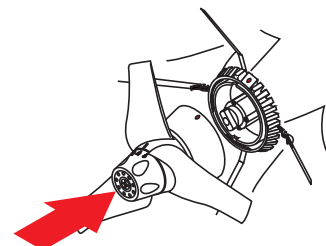

Maintenance

Note on Maintenance and storage.

■STEP1 The main sealing O-rings.

There are four main sealing O-rings. Two large O-rings between the top cover (head Assy) and body Assy, and two smaller ones between the body Assy and propeller Assy.

You must replace these O-rings if they are in any way damaged, deformed, or creased.

We highly recommend that these O-rings be changed annually.

Please use an O-ring pick made of soft plastic when removing the O-ring from the groove.

Please never use a screwdriver or a sharp tool.

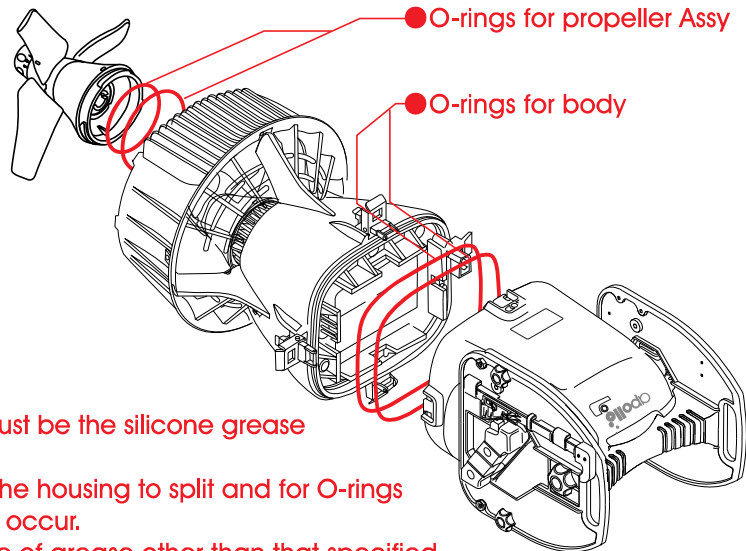

⚠ CAUTION

- The grease used for lubrication of the O-rings must be the silicone grease specified by Nippon Sensuiki.

Other types of grease can cause the plastic in the housing to split and for O-rings to expand which may cause serious leakage to occur.

Please note that the damage caused by the use of grease other than that specified by Nippon Sensuiki will void any warranty.

■STEP2 Body

Impact absorbent acrylonitrile-butadiene-styrene resin is used for the body of the av-2 series, AVX and scooter saddle.

This material excels in strength and durability, and looks great after years of service.

However, the material may be seriously compromised and damaged if you use the wrong lubricants and or cleaners. Please note the following.

⚠ CAUTION

- Please never use organic solvents such as gasoline, oil, petroleum, grease (Vaseline included), alcohol, the toluene, methyl, ethyl, ketones, and acetones nor strong detergents, etc.



■STEP3 Accelerator unit

Please execute "Desalt" process on all moving parts.

Especially the accelerator lever.

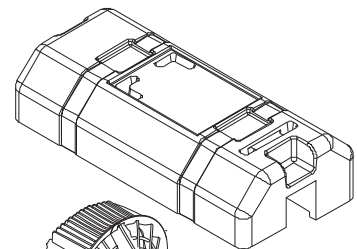

■STEP4 Storage notice

- Please disconnect the plug from the battery during storage.

- Please keep the box the scooter is delivered in. This box will help prevent damage during transport.

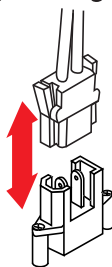

Remove the battery socket

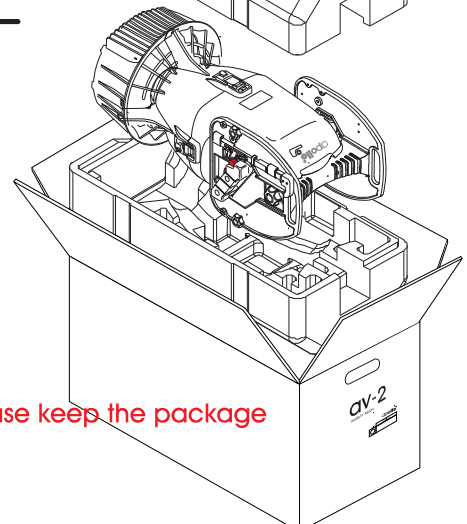

Please keep the package

Trouble shooting

Symptoms : The propeller doesn't rotate even though the accelerator lever is activated.

Check1 : The scooter won't activate.

- Please confirm the battery indicator lights are on.

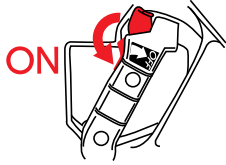

- Action when trouble is found.
Please turn the main switch on.

Please go to the following step if the scooter still does not operate.

Check2 : The battery may not be connected correctly.

- Please open the head assy and confirm that the battery lead is not connected.

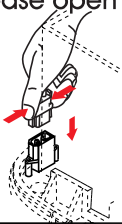

- Action when trouble is found.
Please connect the battery connector correctly.

Please go to the following step if the battery is connected correctly.

Check3 : Can you push the red accelerator unit switch button on the side of the scooter main body down firmly?

- Visually confirm the operation of the switch.

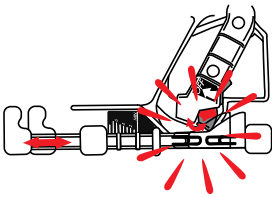

- Action when trouble is found.
Normal operation can be expected after repair.
Please request your local dealer to repair the scooter if you do not understand the repair method.

Please go to the following step if the accelerator seems to be working correctly.

Check4 : Is the battery charged?

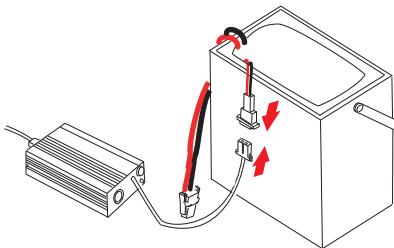

- Action when trouble is found.
Please recharge your existing battery and try again.

If the symptom still persists after another fully charged battery has been tried then please go to the next step.

Check5 : The water sensor may have been activated.

- Please open the head Assy cover, and confirm the warning lamp is on.

- in case of avx please refer to P. 14 ⑤.

- Action when trouble is found.
Please dry around two sensor screws that are located on the top of the bulkhead.

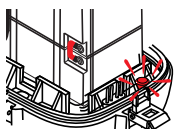

Water leak alert lamp

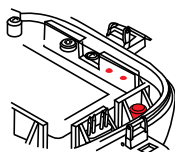

Water leak sensor terminal

If the warning lamp has not turned off, or the warning lamp lights up frequently, the scooter may be leaking.
Please request a full overhaul with your dealer.

Please go to the following step if this sequence of troubleshooting doesn't correspond.

Please advise the dealer that the scooter is not operating even after all the above points were addressed and checked.

• • • • **Diving for the future**

U.S.A.
Apollo Sports USA, Inc.
12310 Hwy 99, #107, Everett, WA 98204
Tel 800 231 0909
Fax 877 756 7240
<https://www.apollosportsusa.com/>

JAPAN
Nippon Sensuiki Co. Ltd.
905 Shake, Ebina-City
Kanagawa-Pref, 243-0424, Japan
Tel 046-233-4111
Fax 046-233-5886 

