

# introduction

Congratulations on the purchase of your APOLLO scooter, The APOLLO av-1 scooter is an underwater scooter developed to meet the needs of divers wanting to go further and faster in the water, The APOLLO av-1 scooter can be used with a minimum amount of kicking, allowing you to conserve about 50% of the air you normally consume when just using fins. Through the use of the 3-stage variable pitch propeller, it is possible for you to adjust the speed to match your various diving plans, The body of the APOLLO av-1 scooter was hydrodynamically designed, making it more compact and lighter weight than previous underwater scooters. It is easy to carry on land and has total response in the water. In terms of safety, APOLLO's unique double water-proof structure protects the motor, gears and battery from water leakage and obstruction by foreign objects, If, by chance, water leaks into the housing or if there is overheating, the rapid sensor functions protect the diver and machine from major damage. In addition, as part of APOLLO's total design approach, the scooter is equipped with an option panel (separately purchased) which includes a depth gauge and compass. A system light, gauge and other devices can be attached to the scooter or body as the diver sees fit.

For safe and comfortable diving, read the instruction manual prior to use. If you have any questions regarding the product, refer to the store where it was purchased.

# apollo scooter av-1 CONTENTS

## specifications

- names of each part / apollo av-1 scoote ..... 34
- names of each part / battery charger av-310 ..... 35

## preparation

- battery charging ..... 36
- checking before use <Setting> ..... 44
- checking before use <Confirming operations> ..... 46

## use

- for safe diving ..... 48
- method of operation ..... 49
- safety devices ..... 53

## maintenance

- after-use care ..... 54
- care and storage and related precautions ..... 56

## trouble shooting

- motor abnormalities ..... 58
- abnormalities from leakage ..... 59
- abnormalities during operation ..... 60
- charger abnormalities ..... 61

# specifications

## names of each part / apollo av-1 scooter

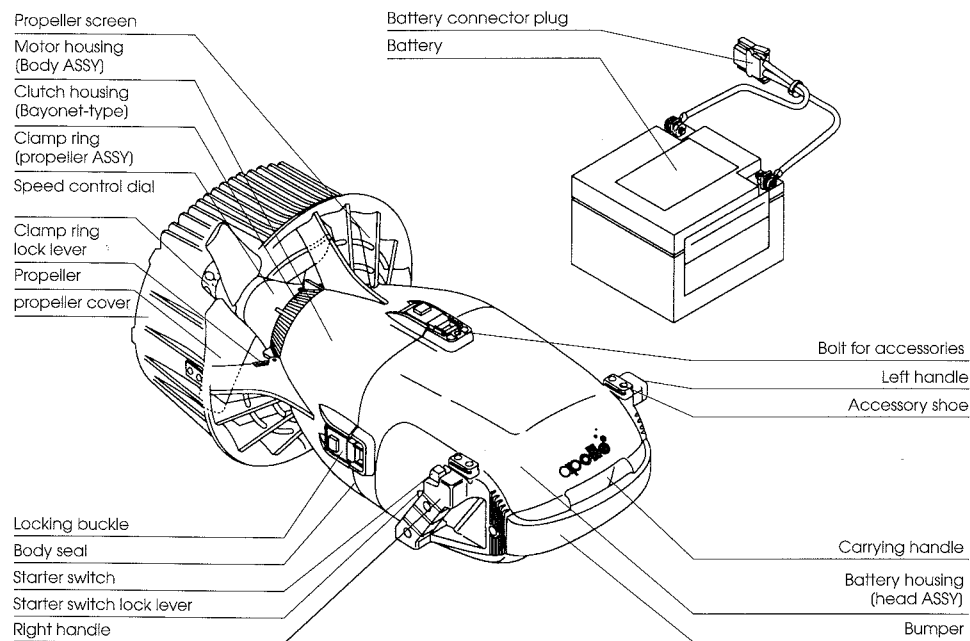

### ■ apollo av-1 scooter

Width and length	:34X61cm	Motor	:DC 12V magnetic field-type motor
Total weight	:approx. 18kg (40LBS)	Speed reducer	:Ring epicyclic gear speed reducer
Battery weight	:approx. 8.6kg (19LBS)	Speed adjustor	:Variable pitch-type propeller
Weight in water	:approx. 650g (1.5LBS)	Safety devices	:Thermal switch function automatically shuts down operations when internal temperature rises, :Water seepage sensor function turns on warning lamp when there is water seepage in the motor or battery housing and automatically shuts down operations.
Speed	:1.8-4.0km/h (18~40LBS)		
Operation time	:25 - 60 minutes (2.5miles)		
Pulling force	:8 - 18kg		
Active range	:approx. 4km		
Recharging time	:5 - 9 hours		
Body	:Shock resistant ABS resin		
Battery	:Shin-Kobe Electric Machinery CO., Ltd. HP24-12 Sealed Lead-Acid Battery, 12V24AH		

\*Use only the auxiliary battery or other separately purchased batteries designated by APOLLO.

\*When charging batteries, use the auxiliary battery charger AV310. Do not use other chargers.

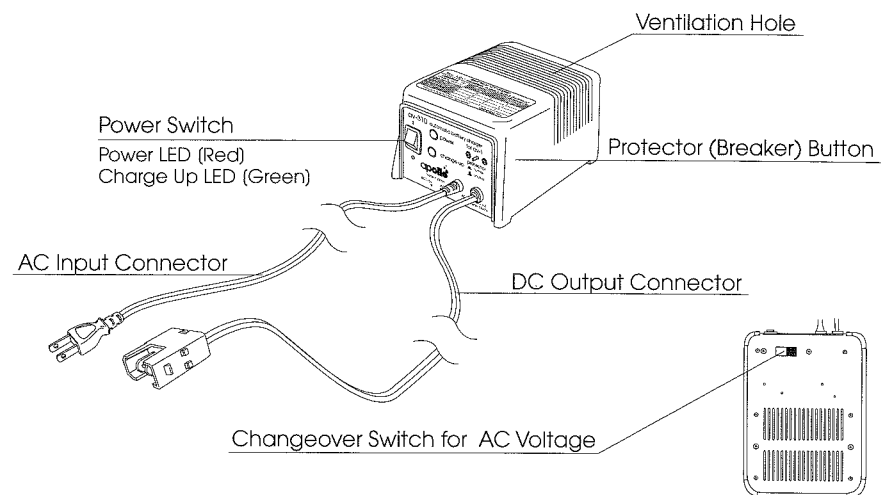

### ■ battery charger AV-310 Outside dimensions: 8.3cmX11.0cmX16.0cm

Output voltage current: DC12V/2.8A  
 Input voltage: AC115 or 230V 50/60HZ  
 Indicator: Power/red, Charge up/green  
 Safety devices: Protector inside casing

\*Only use this charger for the auxiliary battery and other separately purchased batteries designated by APOLLO.

\*Always check voltage setting on charger before use to avoid damage. The AV-1 is designed for use worldwide, the charger can be set for use in a 115 or 230 volt situation. Always use correct setting to avoid permanent damage to battery and charger.

### ■ auxiliary items / separately purchased accessories

- Two types of body seal-type spare O-rings (one of each type)
- Silicon grease
- Float

# preparation charging battery

## 1 Preparation for charging.

When purchased, the scooter battery may have naturally discharged, making it necessary to recharge before using.

- Stand the scooter upright with the propeller cover on the bottom.
- Watch the propeller when standing the scooter upright. When doing this outside, be careful not to bend or otherwise damage the propeller on rocks or similar potentially hazardous objects.

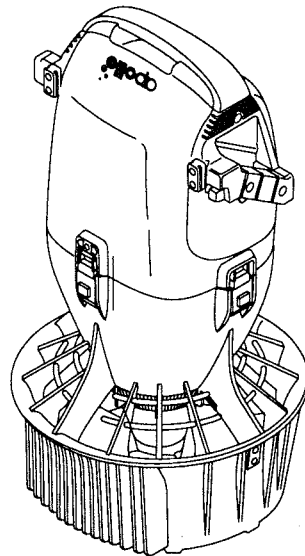

Stand the scooter upright.

## 2 Unfasten locking buckle.

A lock structure is attached to the locking buckle to prevent the buckle from releasing as a result of unexpected shocks.

Unfasten four locking buckles on the body seal.

- First, while pushing the square button in the center of the locking buckle, lift the end of the buckle.
- Next, after releasing the buckle hook, flip the buckle downward. Release all four parts.

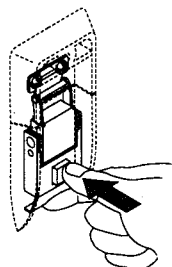

Push the square button.

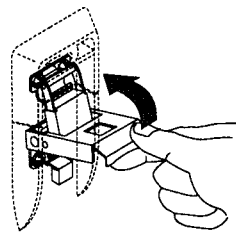

Lift upward.

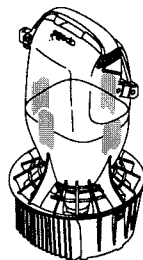

There are buckles in four places.

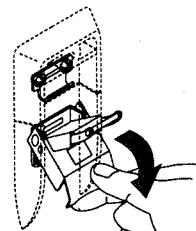

After releasing the hook, flip downward.

## 3 Remove battery housing.

It may be difficult to remove the battery housing (head ASSY) due to negative pressure inside the body caused by contact with the O-ring, temperature variation and other factors.

- In this case, pull buckle while pushing locking buckle arm in front of hook as shown in the diagram. By doing this, it can be easily released.

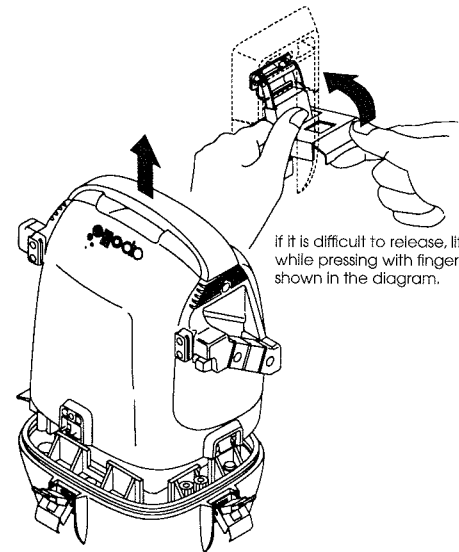

If it is difficult to release, lift while pressing with fingers as shown in the diagram.

Release battery housing (Head ASSY).

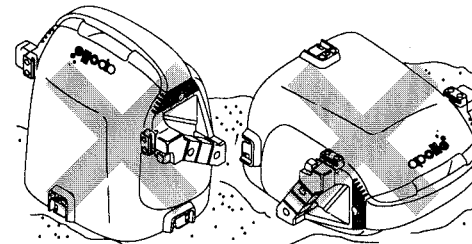

Do not set in sand or on other unsanitary surfaces.

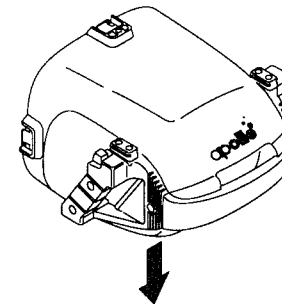

Set with guard ribs turned downward.

## 4 Precautions concerning the handling of housing after removal.

Silicon grease is coated on the battery housing (head ASSY) seal joint. Sand and other debris easily stick to this. Be careful to avoid this situation.

- Water leakage is caused almost entirely by the adherence of foreign matter.
- Be careful not to let sand and other debris adhere to seal joint.
- Put battery housing (head ASSY) in place immediately after removing battery.
- Do not place on sand or similar surfaces.
- After removing battery housing, place it so that the side with guard ribs is turned downward. Avoid places with sand or other debris. Set on a clean surface.

# preparation

## battery charging

### 1 Precautionary matters when recharging.

When recharging, a small amount of hydrogen gas is released. For this reason, strictly observe the following precautionary matters when recharging.

- Avoid recharging in a closed room. Recharge in an area with good ventilation.
- Do not recharge in areas warmer than 40 (104°F) degrees Celsius, such as places with direct sunlight or in heater or boiler rooms. (The ideal temperature for recharging is between 20 and 30 degrees Celsius.) (68-86°F)
- At low temperatures (approximately zero (32°F) degrees Celsius), it takes up to two hours longer to recharge than under ideal temperatures. Batteries should be recharged at ideal temperatures.
- When recharging, do not smoke, conduct operations near a fire or expose equipment to any similar dangers.

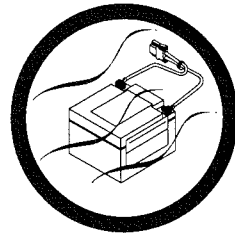

Recharge in an area with good ventilation.

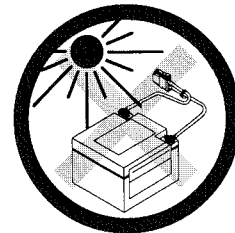

Avoid areas with direct sunlight of high temperatures.

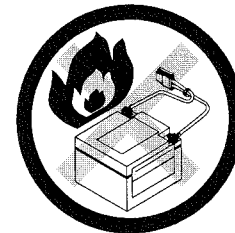

Do not set equipment near fire.

### 2 Discharged battery.

When recharging a discharged battery, the charger becomes quite warm, but the temperature decreases as the battery is charged.

- Do not cover draft hole while charging. Overheating may damage the charger.

**Caution: The battery naturally discharges. For this reason, if the scooter is not used for a long period (approximately two weeks) the battery should be recharged. If the battery is left uncharged, it will become excessively discharged, reducing the life of the battery.**

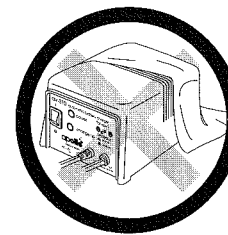

Do not cover draft hole.

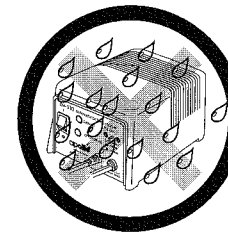

Do not expose to rain, salt water or other kinds of moisture.

### 3 Basic structure of the charger.

The charger is not a water-proof. It should be used in an area which is sheltered from rain and sea water.

# preparation

## battery charging

### 1 Releasing the battery connector plug.

When shipping, the battery connector plug is removed.

- Grab the hook levers on both sides of the battery connector plug and pull upward.

**Caution: Altering the battery connector plug is very dangerous and should not be done. Doing so will cause unexpected trouble.**

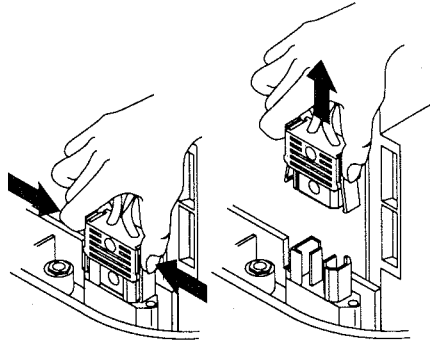

Grab both sides of hook lever and remove.

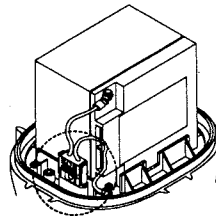

### 2 Removal of battery.

- Hold battery securely in both hands and pull out of the body.

**Caution: The battery is quite heavy, so be careful not to get your fingers pinched or to drop it on your foot.**

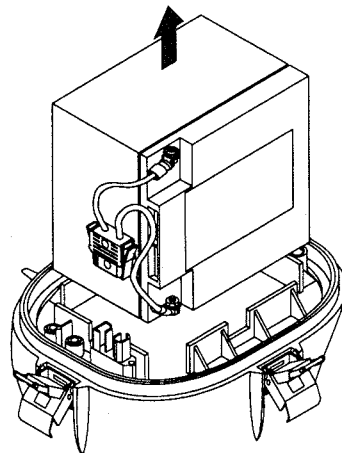

Remove the battery.

### 3 Connect the charger and recharge.

Do not use any charger outside of the auxiliary battery charger AV-310.

- First, insert plug in household outlet (AC).
- Next, Connect the battery connector plug and the DC 12V output connector of the charger (receptacle).

The connector is polarized, so when connecting, insert in a direction so that it will smoothly enter the outlet.

Always check voltage setting on charger before use to avoid damage. The AV-1 is designed for use worldwide. The charger can be set for use in a 115 or 230 volt situation. Always use correct setting to avoid permanent damage to battery and charger.

Trouble resulting from the use of a battery charger other than an AV-310 charger is not subject to guarantee. Sufficient precautions should be taken.

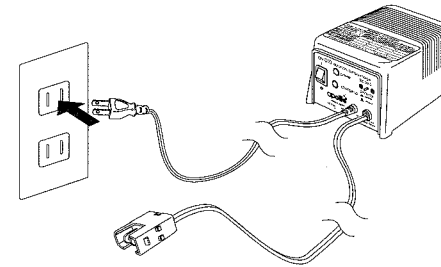

First, insert charger plug into on proper AC.

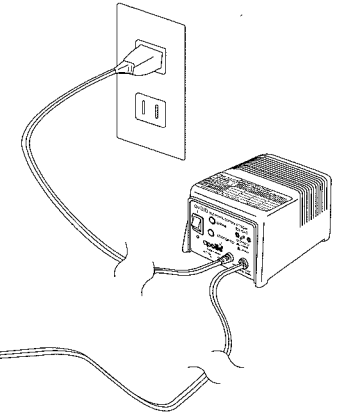

Next, Connect the two cords together.

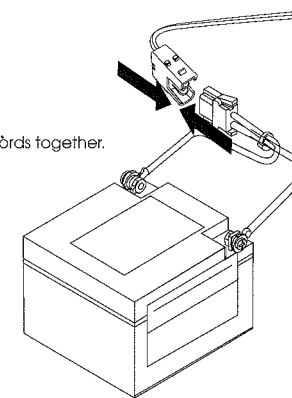

# preparation battery charging

## 4 Charging time of charger.

Condition:

1. Turn on the power switch, after connect the household outlet and battery.
2. The battery is being charged when the power lamp on.
3. The battery is being constant voltage charged when both of the power lamp and charge up lamp are turned on. (This is completed charging 90-95%.)
4. 5-9 hours later, only the charge up lamp is turned on. It means that the charging is completed and the power is turned off.

	Power	Charge up	Conditions
	Off	Off	1
Charging	On	Off	2
Constant Charged	On	On	3
Completed	Off	On	4

• It is able to finish the charging when the charge up lamp is turned on. However, it is better to keep charging until the condition 4, because of the battery protection.

## 5 Removing charge after charging is complete.

The battery charger AV-310 will not damage the battery if left connected after the completion of charging automatic shut off prevents over charging.

- When charging is completed, turn off the power switch.
- Detach the battery connector.

**Caution!** After charging is completed, remove the battery connector cord and let sit for at least 30 minutes. Then, set in scooter. After charging is complete, hydrogen gas is released for a short time. Be careful not to have any flammable objects in the vicinity.

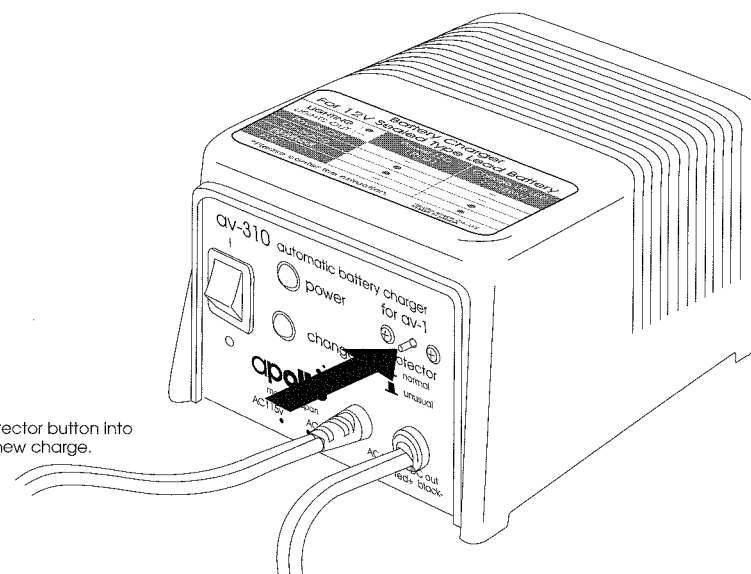
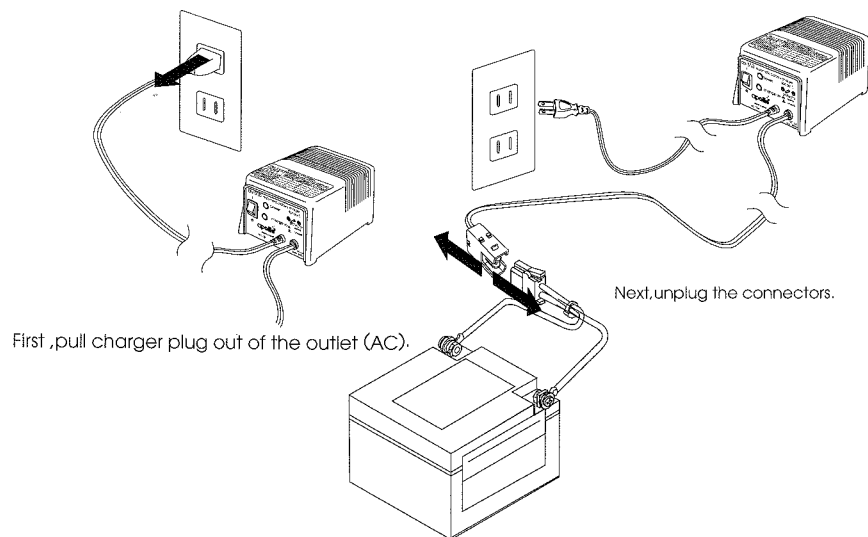

Press protector button into begin a new charge.

## 6 Protector.

- The protector button pops out when a discharged battery is fully charged.
- Press protector button in to begin a new charge.
- If some malfunction, excess current, or other trouble arises the protector pops out and the power shuts off.
- If the protector pops out unexpectedly; confirm voltage is set properly, and that there is no short in the battery cord, connector, or other parts. Then press the protector several times to reestablish charging.
- If the protector pops out again, this could indicate trouble with the battery, connector, or charger. Consult with the store where purchased.

# preparation

## checking before use <setting>

### 1 Checking and setting battery.

Charge the battery with the auxiliary battery charger AV-310 and confirm that the FULL lamp is turned on. The battery should be fully charged before using.

- If there are no problems, set the battery so that the connectors of the body and the battery cord line up as shown in the diagram.
- Next, connect the connector (remove when not in use).
- At this time, confirm that the warning lamp (refer to page 51) is not turned on. If the lamp is on, there may be water leakage. Do not use if this is the case. Take appropriate measures according to the section on use and safety devices on page 51.

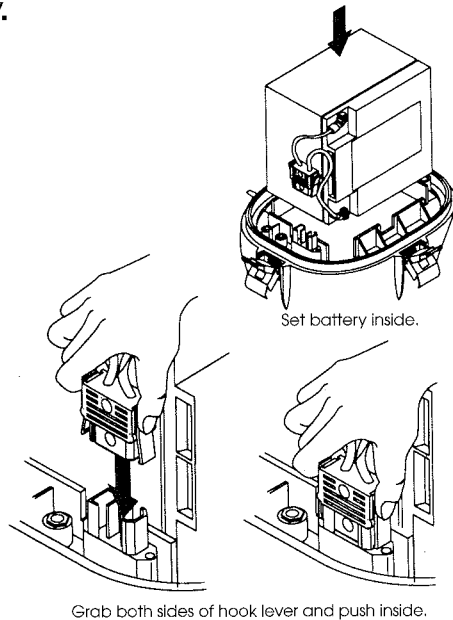

### 2 Setting battery housing.

Confirm that there is no debris adhering to the O-ring, O-ring groove or O-ring connecting surface. Also confirm that there are no scratches and that there is an appropriate amount of silicon grease coated on.

- Cover with battery housing (head ASSY).
- Close the locking buckles at all four locations on the body.

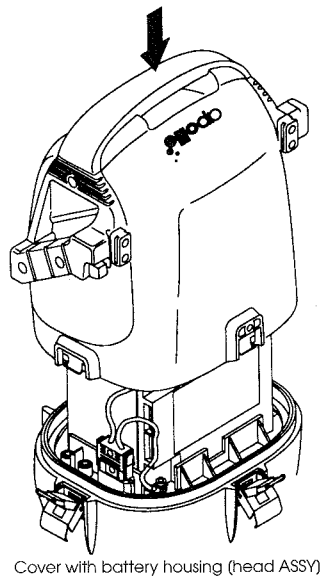

### 3 Checking the housing seal.

After setting the housing, confirm that there is a uniform space of 1mm between the battery housing (head ASSY) and the motor housing (body ASSY).

- If the space is less than 1mm or if the two parts are joined, there is the possibility of the O-ring coming out of the O-ring groove. Confirm that this is not the case.

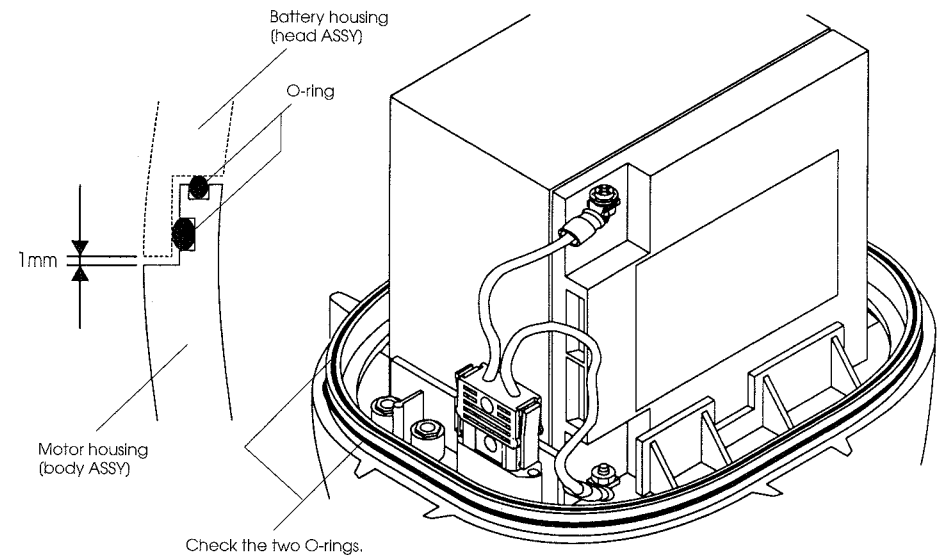

### 4 Checking the locking buckle.

- Lastly, confirm that the four locking buckles have been securely locked.
- If there is a gutter attached, readjust from the outset. In particular, confirm that there is no O-ring abnormality.

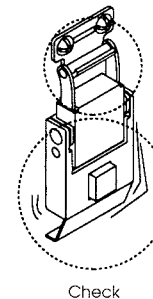

# preparation

## checking before use <confirming operations>

### 1 Confirming safety.

- Confirm that there is nothing in the vicinity of the propeller. Clear away anything which may get entangled in the propeller.

Keep hands and other objects away from the propeller.

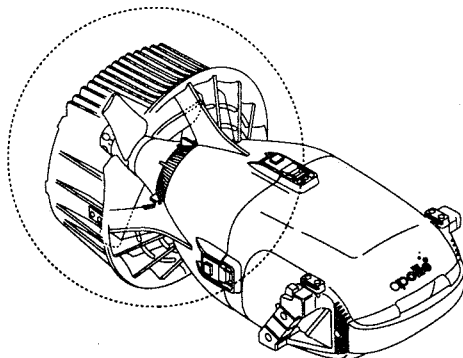

### 2 Releasing the lock of the starter switch lock lever.

- Turn down the under part of the starter switch lock lever in the direction where it can tucked inside of the handle to release the lock.
- Keep the lock released while using.**

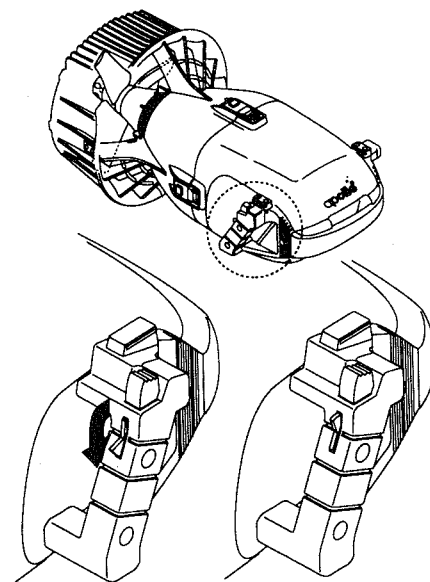

Release the lock.

### 3 Starting the motor.

- Start the motor by pushing the starter switch on the right side of the handle and confirm that the propeller is revolving.

**Caution:** Do not let the motor run longer than 10 seconds outside of line water. Doing so may cause damage to the propeller shaft seal. Keep hands and other objects away from the propeller while it is operating.

- Confirm that there are no unusual sounds coming from the motor or clutch housing (propeller ASSY).

**Caution:** In case of an unusual sound, stop the motor and ask the store where the scooter was purchased to fix the problem.

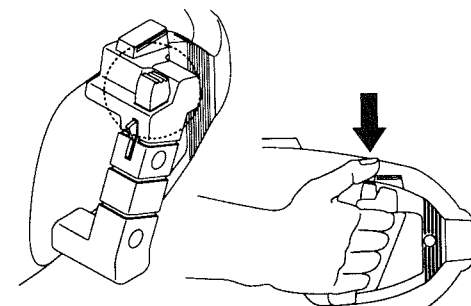

Push the starter switch.

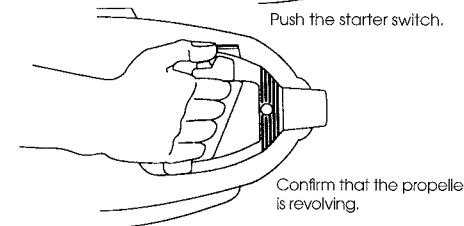

Confirm that the propeller is revolving.

Do not let run for longer than 10 seconds.

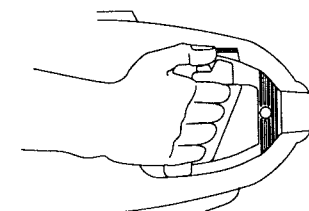

Release the starter switch.

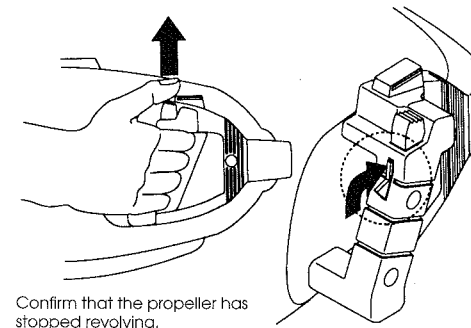

Confirm that the propeller has stopped revolving.

Lock when not in use.

### 4 Stopping the motor.

- When moving hands away from the starter switch, confirm that the motor has automatically returned to OFF.

**Caution:** To ensure that the switch does not start accidentally, lock the starter switch lock lever when not in use.



# use for safe diving

## 1 Precautions while operating. 2 Skilled diving with the scooter.

Operation of the APOLLO av-1 scooter can be mastered in a short period of time. However, read this manual carefully and understand the following precautionary matters before using.

- Do not use at a depth of more than 40m (130ft).
- Be careful not to let strings, hoses, hair, hands and other objects get entangled in the screws.
- Do not let the motor run for longer than 10 seconds outside the water.
- When the sound of the motor changes and the pulling force decreases during operation, this is a warning that the battery is discharged. Do not continue to operate.
- If the battery is repeatedly discharged, its life will be reduced. For this reason, the scooter should be operated while the battery is fully charged.
- When not using the scooter, stand it up in a safe place with the propeller facing downward. At the surface of the water, securely fasten with a rope. To ensure that the motor does not start when you are unprepared, lock the starter switch lock lever.
- The body seal and the clutch housing seal are important in maintaining water resistance. Pay special attention to the handling of these parts.
- When operating near the water surface, confirm that the propeller cover is securely below the water surface beforehand. When the propeller is above the surface of the water, the propeller becomes unbalanced, causing the propeller shaft to vibrate and water to leak. Do not let the propeller operate above the surface of the water.

Strictly observe diving rules. The APOLLO av-1 scooter can be used with minimal kicking. For this reason, the amount of air consumed can be reduced by about 50%. This feature has made it possible to dive for long periods of time over a wide region of the ocean. This makes it all the more important to observe safe diving rules.

• Before entering the water, carefully make a diving plan. Carefully study the water depths of the region or consult with someone who is knowledgeable about the relevant region. Plan for marginal error in terms of safe depths, descension time, range of movement and other matters.

- Do not dive alone.
- Do not go below 40m (130ft).
- Do not exceed a rate of descension of 60ft a minute or a rate of ascension of 74ft a minute. This as well as the holding breath while ascending is a major cause of accidents. Divers should continue the breath normally while operating the scooter.
- **The 1/3 principle used by cave divers:** Use 1/3 of the air while moving to the destination and 1/3 while returning. Save the remaining 1/3 as reserve air.
- A propeller cover is attached to keep foreign matter from obstructing the propeller. However, areas which are dense in seaweed and algae are extremely dangerous and as such, should be avoided.
- When entering the surface of the water with a concentration of seaweed, the diver should pull the scooter down and start it after clearing away the seaweed. The diver should ascend in an area where there is no seaweed.

## 3 Entering from the shore. 4 Entering from a boat.

- Enter the water while holding onto the carrying handle.
- In waist-deep water, go under water and start the scooter.
- When using the scooter near the water surface, submerge the propeller cover well below the surface of the water before using to ensure that there is no racing or loss of thrust.
- When exiting, coming to a shallow place near the shore makes it easy to operate. After reaching a shallow area, grab the carrying handle, get out of the water and carry the scooter to a place where it can be safely stood up.

**Caution: It is dangerous to throw the scooter in the water by itself from a high place. This should not be done.**

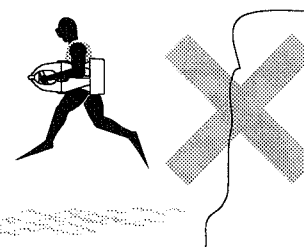

Do not jump into the water from a high place while holding the scooter.

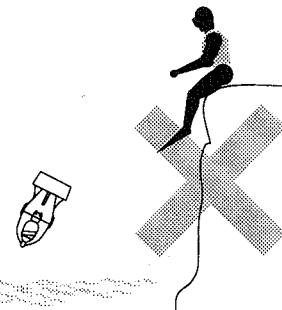

Do not throw the scooter in the water from a high place.

- Do not enter the water from a boat while holding onto the scooter.
- Before entering, tie the scooter with a rope and lower it into the water or have it handed to you after entering the water.
- When receiving the scooter, lower the scooter into the water at a height which makes it easy for the person in the water to grab the carrying handle.

**Caution: It is dangerous to pass the scooter by the side handle. Doing so may accidentally turn on the starter switch causing the motor to suddenly start.**

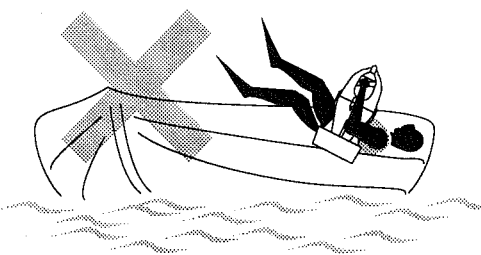

Do not enter while holding onto the scooter.

# use method of operation

## 1 switch operation.

- Release starter switch lock lever.

Switch ON: Press the starter switch on the right handle with fingers. When the motor is in operation, the switch is ON.

Switch OFF: When releasing fingers from the starter switch, the switch automatically returns. When the motor stops, the switch is OFF.

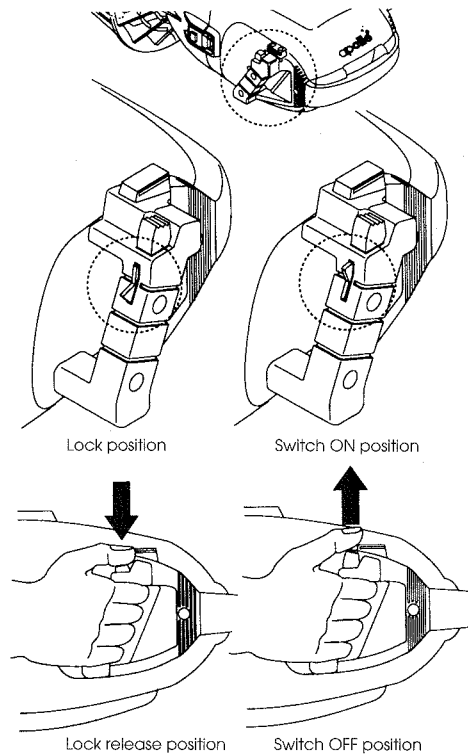

## 2 Starter switch trouble.

- When the starter switch is not operating smoothly, it may be an indication that debris or sand is caught between the starter switch and the handle. In this case, rinse with tap water.
- There is a strong magnet set up inside the starter switch for operating the reed switch. If iron sand clings to this magnet, operation of the starter switch may worsen. The customer cannot repair this. In such an event, consult with the store where the scooter was purchased.

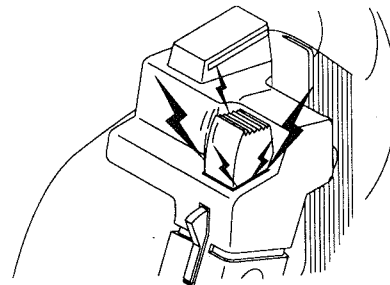

## 3 Riding position.

To efficiently operate the scooter, it is best to position yourself in such a way as to create the least resistance and to operate with ease. Prevent arms and body from blocking the flow of water through the scooter propeller.

### 1. Operating in a straight line at fast speeds.

Hold the scooter parallel to your body and extend your arms. Hold the scooter somewhat lower than your body and position the screw so that it freely thrusts backward. Extend fins straight. There is no need to kick. The diver should practice positioning his/her body to ensure the least resistance. When operating in the ideal position, the diver can operate the scooter at a safe speed without getting tired.

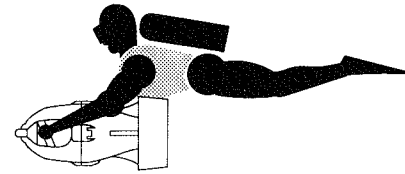

### 2. To operate with little effort.

Hold the scooter parallel to your body, set your stomach on the deck portion of the propeller, bend your elbows and hold the scooter with your arms.

Caution: If your body comes too close to the body of the scooter, it interferes with the stream of water entering the screw, thus decreasing the operating efficiency. Sufficient care should be taken not to get gauges, octopuses, dive notes and other devices entangled in the propeller.

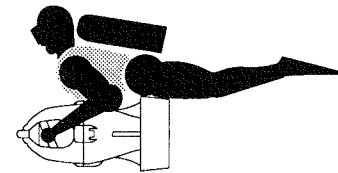

### 3. Poor riding position.

Do not position your body perpendicularly to the scooter. Doing so acts against the thrust, decreasing speed and efficiency. Furthermore, this position causes your body to become cold due to the stream of water from the propeller.

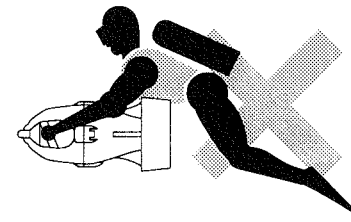

## use method of operation

### 4 Method for changing directions.

To change water depths, sufficient care should be taken not to exceed safe rates of ascension and descension. If you experience any discomfort in your ears, immediately turn the scooter off and clear your ears.

- Point the scooter in the desired direction.
- To rotate widely from left to right, it is possible to make a smooth rotation by letting the center of your body fall in the desired direction like in aircraft.
- To turn the scooter at a sharp angle, move the scooter away from the body slightly and turn it in the desired direction.

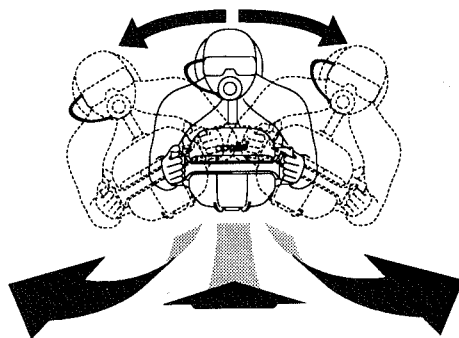

### 5 Speed control dial operations.

By using the 3-stage variable pitch method, it is possible to vary the propeller pitch angle and adjust the scooter speed. The number indicated on the speed control dial shows the speed. The variable pitch propeller effectively moves with the body when diving. It is possible to adjust the differences in speed due to differences in physiques and materials being pulled by adjusting the propeller pitch. This allows two different divers to travel at the same speed.

- Turn the speed control dial while pulling.

1=High speed (operate for short periods at high speed)

2=Mid speed

3=Slow speed (operate for long periods at low speed)

- Adjust the dial to the desired speed. After turning, release your hand and the dial will return by a spring device. Confirm that it is engaged.

- While diving, it is possible to change the speed and adjust the operating time. In such a case, temporarily stop operations and adjust the propeller pitch as described above.

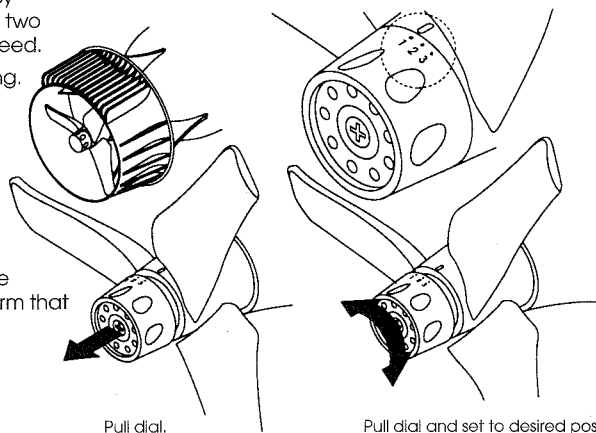

Pull dial.

Pull dial and set to desired position.

## use safety devices

### 1 Stopping of motor by thermal switch.

In order to prevent any negative influence to the battery, motor or electronic parts resulting from an increase in temperature inside the scooter, a thermal switch safety device is installed.

- If the motor overheats as a result of long continuous operation, or if the temperature inside the housing rises above the necessary level, the safety device turns on and the motor automatically shuts off.

In this case, let the scooter naturally cool before using.

- The safety device also turns on if the temperature inside the housing rises as a result of the scooter being set under the scorching sun, in a car or any other place subject to high temperatures. If the scooter is unable to start, this is the likely cause. Let the scooter cool in shade or water and try again.

**Caution:** When the temperature inside the housing rises above 60 degrees Celsius (140° F), hydrogen is released from the battery, creating a hazardous situation. The battery should be stored in a place that is shaded from the sun and subject to little heat increase.

If the motor remains unable to operate even after cooling, lift it directly out of the water by the carrying handle. Following this, measures should be taken in accordance with the matters mentioned in the trouble shooting section.

### 2 Stopping of motor by water leakage sensor.

If water leaks into the scooter, it may cause damage, explosions or other serious accidents. To prevent this, a water leakage sensor and warning lamp are installed.

- If water permeates the battery housing (head ASSY) and motor housing (body ASSY), the water leakage sensor is activated and the motor shuts off.

In this case, the warning lamp on the wall of the motor housing (body ASSY) turns on to warn of water leakage.

- When the warning lamp (red) is on, do not turn switch on.
- Sufficiently wipe the moisture from the inside of the battery housing. In particular, use a dry cloth to wipe the moisture from the two plus bolts horizontally and to the right of the warning lamp.

**Caution:** If the light does not turn off after having done this, there is probably water inside the motor housing (body ASSY). The owner is unable to analyze and repair this. The scooter should be taken to the store where it was purchased.

Even if the motor operates after wiping up the moisture, it should not be used before investigating the cause of the water leakage and taking adequate measures.

Once water has entered the motor housing, it cannot be removed. Therefore, even if the warning lamp does not turn on, do not turn the motor on. Doing so may cause an explosion.

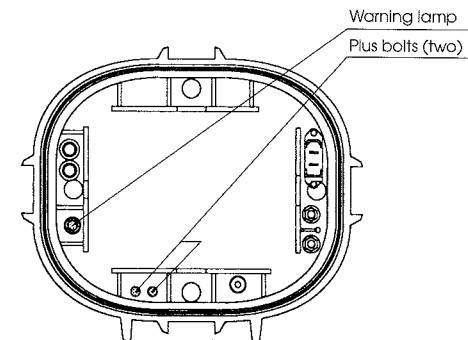

Warning lamp  
Plus bolts (two)

# maintenance

## after-use care

### 1 Removing salt.

Wash with tap water after use. In particular, rinse sand and other debris from the propeller, starter switch, locking buckle and other parts.

- Remove battery
  - In order to sufficiently remove salt from parts other than the battery, let soak overnight in tap water.
  - After wiping off water, bring to a shaded area with good ventilation, stand upright with propeller turned downward and let dry naturally.
- Recharge battery to FULL within 24 hours after use.**



Sufficiently remove salt.



Rinse with tap water.

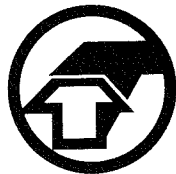

Dry in shaded area with good ventilation.

### 2 Method for opening clutch housing.

After using, water may leak into the clutch housing (propeller ASSY). This needs to be checked.

In order to extract water, remove clutch housing (propeller ASSY) and remove salt water with tap water. If a large amount of water has leaked into the clutch housing (propeller ASSY), discontinue use and bring to store where scooter was purchased for repair.

- Release the clutch lock levers on the right and left and remove the clamp ring lock.
- Next, the lock can be removed by turning the clamp ring counter-clockwise and matching the oval mark on the clutch housing (propeller ASSY) side and the oval mark on the clamp ring side. Remove the clutch housing (propeller ASSY).

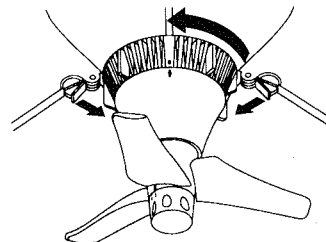

Pull clamp lock lever toward self and turn clamp ring.

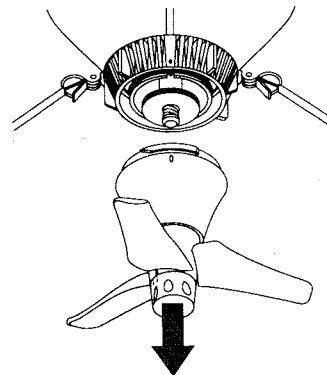

Remove clutch housing (propeller ASSY).

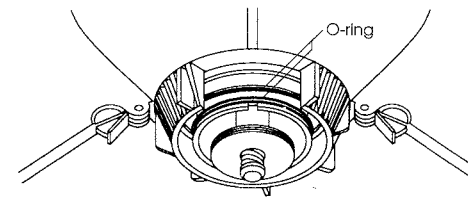

Confirm that there are no abnormalities with O-ring.

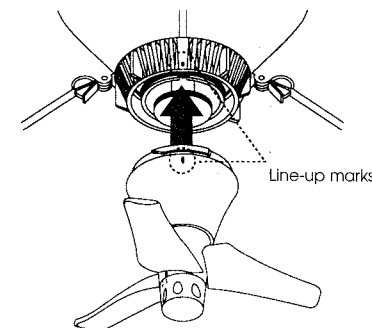

insert clutch housing (propeller ASSY).

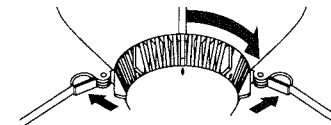

Close clamp ring and push clamp lock lever.

### 3 Method for closing clutch housing.

Set the clutch housing (propeller ASSY) after checking to see that there is no debris or scratches on the O-ring, O-ring groove or O-ring contact surface and after checking to see that there is an ideal amount of auxiliary silicon grease coating. Inadequate checking may result in rusting and therefore incorrect propeller operation. Sufficient precaution should be taken in this regard.

- Confirm that the clamp ring oval marks are turned upward.
- Turn the oval marks on the clutch housing (propeller ASSY) side upward, match with those on the clamp ring side and push together.
- Turn the clamp ring clockwise until it stops turning.
- Lastly, push in the clamp lock lever and lock the clamp ring.

If the clamp ring doesn't reach the designated markings even after pushing inward, move the clamp ring slightly to find the entering position.

### 4 Clutch housing role.

Water leaks into the propeller shaft of conventional underwater scooters. This sea water directly permeates into the motor housing causing the motor and bearings to rust. This has led to many accidents.

The APOLLO av-1 scooter has made great improvements in this regard. The propeller shaft has been double sealed and the clutch housing has been installed between the primary and secondary seals. Even if sea water permeates through the primary seal, this small amount is stopped in the clutch housing, making it possible to prevent water leakage into the motor housing.

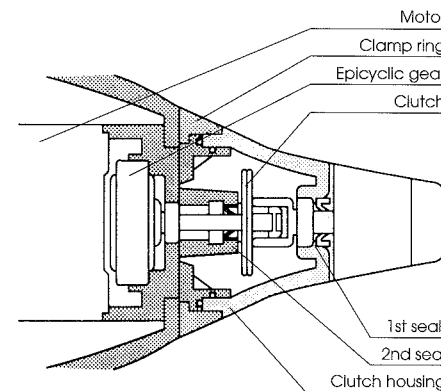

# maintenance

## care and storage and related precautions

### 1 Maintenance for each housing part.

There are two O-rings in the seal part of the battery housing (head ASSY) and the motor housing (body ASSY). There are two O-rings in the seal part of the motor housing (body ASSY) and the clutch housing (propeller ASSY). A total of four rings are used. These O-rings prevent water from leaking into the body of the scooter. For this reason, they must always be given the utmost care and attention.

- Confirm that there is no sand or other debris stuck to the O-ring, O-ring groove or the O-ring contact surface.
- If the O-ring groove or O-ring contact surface is scratched, put plastic putty on the scratched surface and carefully finish it with 600-1200 grain sand paper.
- If the O-ring is scratched, replace with new O-ring.
- Put the appropriate amount of auxiliary silicon grease on the O-ring, O-ring groove and O-ring contact surface. Wipe the excess grease off with tissue paper, gauze or other soft material.
- Do not use anything outside of the auxiliary silicon grease. The use of any other kind of grease may cause damage to the scooter.

**Caution: Note that the APOLLO guarantee does not cover accidents possibly resulting from the treating of the housing with grease other than the auxiliary silicon grease.**

- When removing the O-ring from the groove, do not use a screw driver or any other sharp implement. Use a plastic implement with no angles.

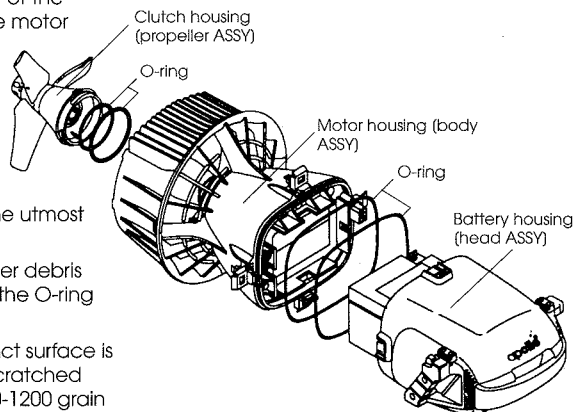

### 2 Care of the body.

Shock-resistant ABS resin is used in the scooter body. This resin has superb strength and resistance and a beautiful appearance. However, if treated with chemicals or other goods, the surface gloss fades and cracking results. For this reason, note the following when caring for the body.

- Do not use organic solvents or strong detergents such as gasoline, oil, petroleum, grease (including Vaseline), alcohol, toluene, methyl, ethyl, ketone or acetone.
- Use the auxiliary silicon grease to lubricate the O-ring, rubber parts of the seal and related plastic parts.

### 3 Care and maintenance of battery.

The APOLLO battery is designed to give maximum performance. In order to maintain this high performance, strictly observe the following precautionary matters.

- Heat deteriorates the battery. Do not leave in areas subject to high temperatures, such as under direct sunlight, near heaters, inside hot cars, trunks or boiler rooms, for a long period of time.

**• Recharge battery to FULL within 24 hours after using scooter.**

- Excessive discharging of the battery (running the motor until it stops) greatly reduces the life of the battery. If the sound of the motor changes while using the scooter, immediately discontinue use and recharge the battery to FULL.

- Do not charge the battery with anything other than the battery charger AV300.

- Charging the battery with anything other than the exclusive charger may result in insufficient or excessive charging, causing the battery to become unusable.

**Caution: Note that damage caused by the use of a different battery or charger is not covered under the guarantee.**

- When the battery is being recharged, slight amounts of hydrogen gas are released. Do not smoke or expose the battery to fire.
- Do not use the charger in an area with poor ventilation and do not block the ventilation hole of the charger case.
- Replace battery after it has been discharged and recharged about 200 times (slightly fewer or greater depending on the conditions of use).
- Longer use than this may result in an abnormally great amount of hydrogen gas during discharging or recharging. This is extremely dangerous and excessive use should be avoided.

**• AS the battery naturally discharges, it should be recharged every two weeks or so even when not being used. If left insufficiently charged for too long, the battery may become excessively discharged, reducing the life of the battery.**

- Do not subject the body of the battery to strong shocks. This may cause damage to the internal parts of the battery or to the functions of the battery.

- Even if not used, the performance of the battery will decrease with the passing of time. After two or three years, the battery has lower capacity than a new battery even if used only a few times. For this reason, we recommend replacing with a new battery.

### 4 Precautions during maintenance.

- Pull out the connector plug for the body and battery.
- Properly take care of the scooter packaging box. Do not dispose of the styrene foam or cardboard box in which the scooter was packed. If by chance the scooter needs to be repaired at a factory, the box is necessary to prevent damage during transport.

**Caution: Damage incurred due to inappropriate packaging when the scooter is returned is not covered under the guarantee.**

# trouble shooting motor abnormalities

## Symptoms

Motor does not run

### Cause

◆ Sudden temperature increase in the housing.

◆ Battery connector damaged.

◆ Battery connector damaged.

◆ Battery dead.

◆ Battery completely discharged.

◆ Power relay damage.

◆ Reed switch damage.

◆ Water leakage.

### Measures

• Discontinue operation and cool inside of housing.

• Confirm connection of battery connector.

• Recharge battery, if unable to recharge, exchange with new battery.

• If motor does not run after lowering temperature in housing and recharging or recharging the battery, bring to store where purchased for repairs.

• Bring to store where purchased for repairs.

• If warning lamp shuts off after wiping place of water leakage, search for the cause before using again.

• If warning lamp does not shut off, bring to store where purchased for repairs.

# trouble shooting abnormalities from water leakage

## Symptoms

Large amount of leakage  
in clutch housing

### Cause

◆ Sand or other debris stuck to or scratches on two O-rings of bayonet.

◆ Foreign matter is entangled in propeller axle seal.

◆ Friction on propeller axle seal.

### Measures

• Clean and grease the surface of the O-ring and O-ring groove. (Exchange O-ring if O-ring is scratched)

• For other matters, bring to store where purchased for repairs.

• Bring to store where purchased for repairs.

## Symptoms

Leakage in battery  
housing

### Cause

◆ Sand or other debris stuck to or scratches on two O-rings.

◆ The surface of the O-rings or O-ring grooves on the top cover or body are scratched or damaged.

◆ Lock buckles do not close sufficiently.

◆ Damage to body.

### Measures

• Clean and grease surface of O-rings and O-ring grooves. (Exchange O-ring if O-ring is scratched)

• For other matters, return to store where purchased for repairs.

• Bring to store where purchased for repairs.

# trouble shooting

## abnormalities during operation

### 1 Sound of motor changes.

When the power capacity of the battery decreases, the sound of the motor becomes lower. Continual use of the battery in this state will need to excessive discharge, reduced life, large emissions of hydrogen gas and other extreme dangers. If the sound of the motor changes, discontinue operation of the scooter, grab by the carrying handle and have the diver pull back and return. The APOLLO av-1 scooter is designed to have low resistance in water and to be lightweight, making it easy to pull.

### 2 Motor makes sounds, but propeller does not revolve.

When the propeller is subject to excessive loads, there is a internal safety clutch which automatically release the propeller from the motor drive line. In these conditions, the propeller stops, but the motor continues to run. Immediately stop the motor and remove the object obstructing the propeller. When the load is eliminated, the clutch automatically shifts into place and operations are able to continue.

**Caution: If these symptoms remain after removing the obstruction, immediately discontinue operations. Lift out of water by carrying handle. Refer to the following flow chart for measures to be taken in response.**

#### Symptoms

**Strange sounds when motor is started**

#### Cause

- ◆ Damage to motor or epicyclic gear reducer.
- ◆ Foreign matter is caught in the bearings.
- ◆ Foreign matter is lodged in the bearings and seal parts holding the propeller shaft of these parts are corroded.

#### Measures

- Refer all matters to store where purchased for repairs.

#### Symptoms

**Motor makes sounds, but propeller does not revolve**

#### Cause

- ◆ Foreign matter is entangled in the propeller.
- ◆ Safety clutch is damaged. (parallel pin is bent, clutch ball has slipped)  
Bring to store where purchased for repairs.

#### Measures

- Remove obstruction. If removal of obstruction does not resolve problem, bring to store where purchased for repairs.

# trouble shooting

## charger abnormalities

#### Symptoms

**Cannot charge by charger**

#### Cause

- ◆ Battery is dead.
- ◆ Battery charger is damaged.
- ◆ Battery is completely discharged.
- ◆ Charger is not set for proper AC voltage.

#### Measures

- Try resetting the battery charger breaker.
- If resetting does not work bring to store where purchased for repairs.
- If repairs do not work, purchase new battery.

**Caution: Damage caused by water leakage into battery recharger is not covered under the guarantee.**

次に示すマークが文頭に付いている文章は、特に気を付けて良く読み、完全に理解してください。

### 危険事項

このタイトルの付いている文章は、守らないと最悪の場合、重傷事故や死亡事故につながる危険性のある、スクーバダイビングに対する知識とスクーバダイビング器材の取扱方法に関する情報について書かれています。

### 警告事項

このタイトルの付いている文章は、守らないと間接的に重傷事故や死亡事故につながる可能性、もしくは重度の物損事故が起こる可能性のある、スクーバダイビングに対する知識とスクーバダイビング器材の取扱方法に関する情報について書かれています。

### 注意事項

このタイトルの付いている文章は、守らないと軽傷程度の事故につながる可能性、もしくは、軽度の物損事故が起こる可能性のある、スクーバダイビングに対する知識とスクーバダイビング器材の取扱方法に関する情報について書かれています。

### 危険事項

●当製品を使用してスクーバダイビングを行うにあたっては、国際的に認知されている潜水指導団体の学科講習および実技講習を必ず受けてください。安全性の見地から、各指導団体の発行するCカード(講習修了認定証)を取得していない方の当製品の使用を禁止いたします。[ただし、各指導団体のインストラクター監督下における講習中の使用は、この限りではありません。]基本的なスクーバダイビングに関する知識が欠如したままダイビングを行うと、重傷事故や死亡事故につながる危険性があります。

(日本スクーバ協会共通掲載危険事項)

●スクーバダイビングを行う際には絶対に一人で潜らず、必ずバディシステムを守るようにしてください。単独潜水は、重傷事故や死亡事故につながる可能性があり、大変危険です。

(日本スクーバ協会共通掲載危険事項)

### 警告事項

●スクーバダイビングを行う際には絶対に一人で潜らず、必ずバディシステムを守るようにしてください。単独潜水は、重傷事故や死亡事故につながる可能性があり、大変危険です。

(日本スクーバ協会共通掲載危険事項)

●スクーバダイビングを行う際には、必ず良好な健康状態で行ってください。少しでも寒気を感じたり、疲れていたり、気分が悪かったりする場合には、絶対に無理を避け、ダイビングを中止してください。

(日本スクーバ協会共通掲載危険事項)

●アルコール類はもちろんのこと、薬品類(特に点鼻薬や風邪薬など)の摂取後はダイビングをしないでください。体調の悪い人や持病のある人は、必ず医師の診断を受けてください。

(日本スクーバ協会共通掲載危険事項)

Items with the following headings describe scuba diving techniques and how to handle diving equipment.

These sections must be completely understood, so be sure to read them with special care.

### DANGER

Failure to obey the instructions under this heading may lead to accidents which result in serious injury or death.

### WARNING

Failure to obey the instructions under this heading may lead indirectly to accidents which result in serious injury, death, and/or serious damage to equipment.

### CAUTION

Failure to obey the instructions under this heading may lead minor accidents and/or minor damage to equipment.

### DANGER

●It is extremely important that scuba divers using this product have undergone theoretical and practical training given by an internationally-recognized entity providing diving instruction.

Due to safety considerations, those who have not obtained a C-Card (attesting to completion of training) from an entity providing diving instruction must not use this product. (This does not apply to those using the product during training, under the supervision of an instructor attached to an entity providing diving instruction.) Amateurs lacking knowledge of basic scuba diving techniques risk serious injury or death.

(A danger item of the Japan Scuba Association)

●Never scuba dive alone. Always dive under the buddy system. Diving alone is extremely dangerous, and could lead to a serious injury or death.

(A danger item of the Japan Scuba Association)

### WARNING

●Make sure you are in good physical condition before you scuba dive. If you begin to feel cold, tired or unwell, do not overexert. Stop your dive.

(A warning item of the Japan Scuba Association)

●Never take alcohol or medicine (especially a nasal spray or medicine for a cold) before scuba diving, those who are in poor physical shape or suffer from some chronic ailment should consult a doctor before considering diving

(A warning item of the Japan Scuba Association)



apollo av-1 scooter

apollo scooter

# av-1 scooter

instruction manual

株式会社アポロスポーツ

神奈川県海老名市社家905 (〒243-0424)  
Phone (046)-233-4111

**Apollo sports co.,ltd.**

905 Shake, Ebina City, Kanagawa, 243-0424, Japan  
Phone (046)-233-4111

3596000004

